

# The 2.0L FSI Turbocharged Engine Design and Function



---

Volkswagen of America, Inc.  
Volkswagen Academy  
Printed in U.S.A.  
Printed 08/2005  
Course Number 821503

©2005 Volkswagen of America, Inc.

All rights reserved. All information contained in this manual is based on the latest information available at the time of printing and is subject to the copyright and other intellectual property rights of Volkswagen of America, Inc., its affiliated companies and its licensors. All rights are reserved to make changes at any time without notice. No part of this document may be reproduced, stored in a retrieval system, or transmitted in any form or by any means, electronic, mechanical, photocopying, recording or otherwise, nor may these materials be modified or reposted to other sites without the prior expressed written permission of the publisher.

All requests for permission to copy and redistribute information should be referred to Volkswagen of America, Inc.

Always check Technical Bulletins and the latest electronic repair information for information that may supersede any information included in this booklet.

Trademarks: All brand names and product names used in this manual are trade names, service marks, trademarks, or registered trademarks; and are the property of their respective owners.

---

# Table of Contents

---

<b>Introduction</b> .....	<b>1</b>
2.0L/200 HP 4-Cylinder Turbo FSI Engine with 4-Valves per Cylinder	
<b>Engine Mechanics</b> .....	<b>3</b>
Crankshaft, Engine Block, Pistons, Engine Balance Shaft, Final Drive Sprocket, Toothed Belt Drive, Cylinder Head, Crankcase Ventilation, Exhaust Turbocharger/Manifold Module, Charge Air Ducting and Boost Pressure Control, Boost Pressure Overrun, Cooling System, Tumble Flaps	
<b>Fuel System Overview</b> .....	<b>16</b>
Demand-Controlled Fuel System, Low Pressure System, High Pressure System	
<b>Fuel System Components</b> .....	<b>18</b>
Fuel Pump Control Module J538, Transfer Fuel Pump G6, High Pressure Fuel Pump with Fuel Pressure Regulator Valve N276, High Pressure Fuel Pump, High Pressure Fuel Pump Operation, Low Fuel Pressure Sensor G410, Fuel Pressure Sensor G247, Cylinder Fuel Injectors N30–N33, Fuel Injector Operation, Pressure Limiting Valve, Connector Fitting with Restrictor	
<b>Engine Management</b> .....	<b>31</b>
Modes of Operation, Actuators and Sensor Diagram, Functional Diagram	
<b>Service</b> .....	<b>36</b>
Special Tools	
<b>Knowledge Assessment</b> .....	<b>40</b>

**New!**

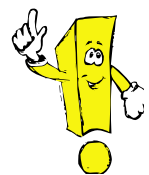

**Important/Note!**



This Self-Study Program covers the design and function of the 2.0L FSI Turbo.

**This Self-Study Program is not a Repair Manual. This information will not be updated.**

For testing, adjustment and repair procedures, always refer to the latest electronic service information.

---

## 2.0L/200 HP 4-Cylinder Turbo FSI Engine with 4-Valves per Cylinder

The 2.0L turbocharged FSI engine is first being introduced to the North American market in the 2005 Jetta and the 2006 Passat.

### Special Features

- Exhaust system with two catalytic converters
- Hitachi ethanol-resistant high-pressure fuel pump
- Returnless fuel system
- Homogeneous fuel injection
- Decoupled final drive sprocket in the balance shaft drive gear
- Elliptical secondary drive wheel on the crankshaft



S339\_046

# Introduction

---

## Technical Data

Type	4 cylinder, inline
Displacement	121 cu. in. (1984 cc)
Bore	3.2 in. (82.5mm)
Stroke	3.7 in. (92.8mm)
Valves per cylinder	4
Compression ratio	10.5:1
Maximum power	200 HP (147 kW) at 5,100–6,600 rpm
Maximum torque	207 ft. lb. (280 Nm) at 1,800–4,700 rpm
Engine management	Bosch Motronic MED 9.1
Camshaft adjustment	42° crank angle
Fuel	Premium Plus unleaded, Premium unleaded, Regular unleaded with slight reduction in power
Exhaust gas treatment	Two three-way catalytic converters with oxygen sensor regulation

## Torque and Power

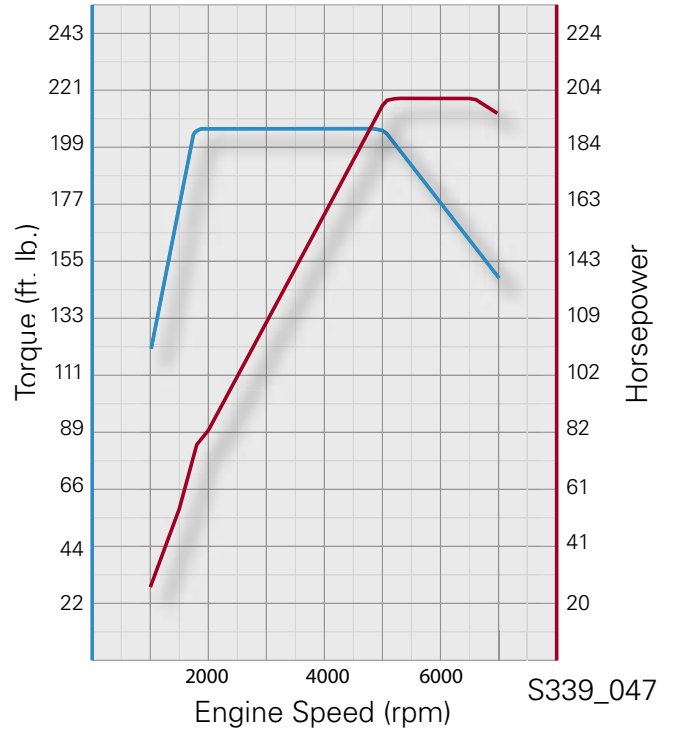

## Crankshaft

The crankshaft meets the tough demands of the turbo FSI engine.

The main bearing flanges and journals are designed to provide as much strength as possible.

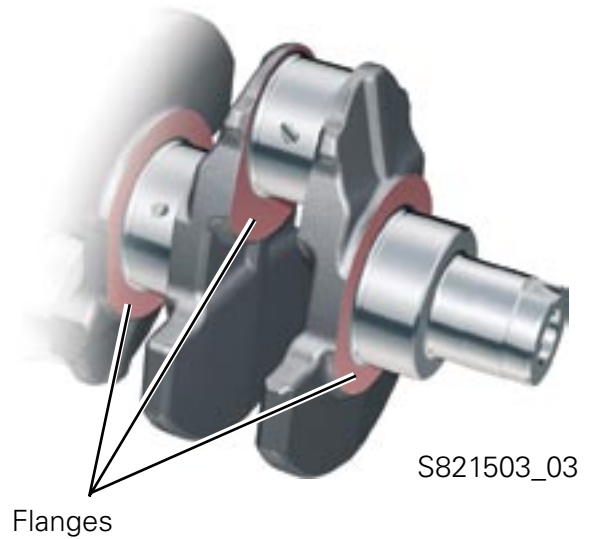

## Engine Block

The cylinder contact surfaces of the cast iron engine block are honed by means of liquid blasting.

This type of honing shortens the run-in time of the engine.



## Pistons

The crown of the piston is designed to enhance combustion.

2.0L 4V T-FSI



# Engine Mechanics

---

## Engine Balance Shaft

The balance shaft assembly used in the engine:

- Optimizes engine vibrations
- Has an oil pump with a wide gear
- Has a pressure control regulator integrated into the balance shaft assembly
- High strength die-cast housing
- Balance shafts mounted in the aluminum housing
- Decoupled final drive sprocket in the balance shaft drive gear

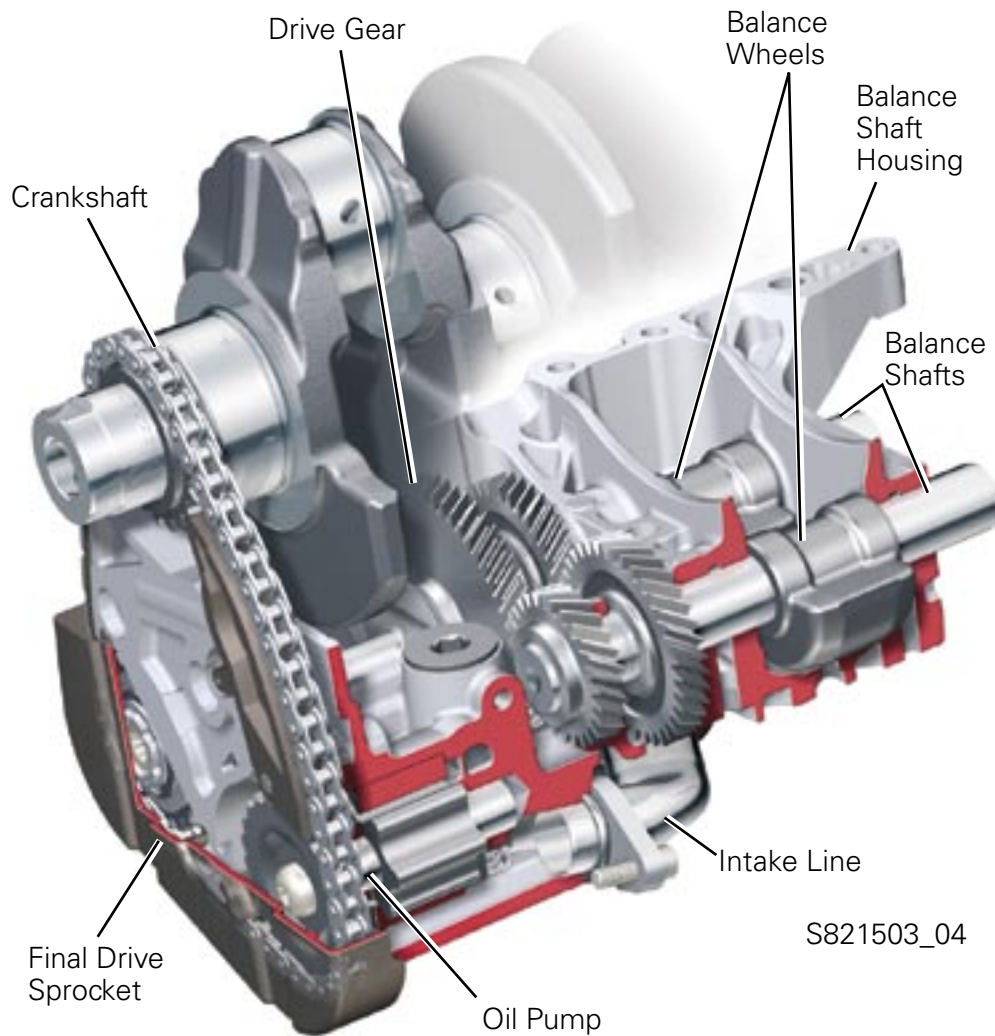

S821503\_04



## Final Drive Sprocket

High torsional irregularities from the crankshaft of the turbo engine at low RPMs result in greater chain forces in the balance shaft chain drive. Bow springs have been integrated into the sprocket wheel hub. They decouple the input shaft of the balance shaft unit from the crankshaft. This is similar to a dual-mass flywheel.

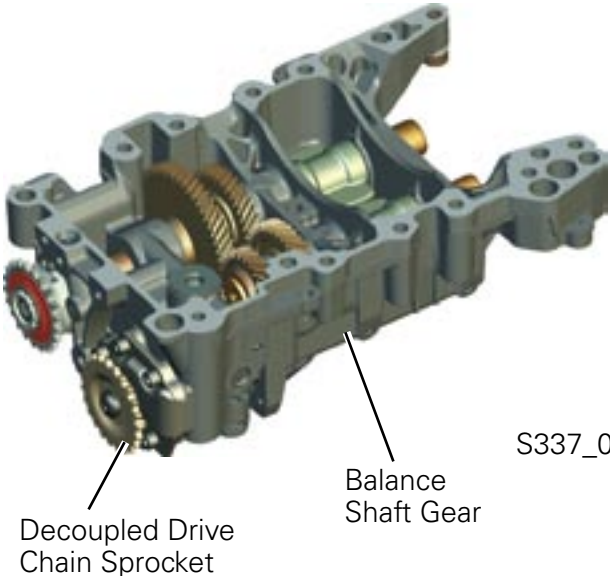

S337\_06

Balance Shaft Gear

Decoupled Drive Chain Sprocket

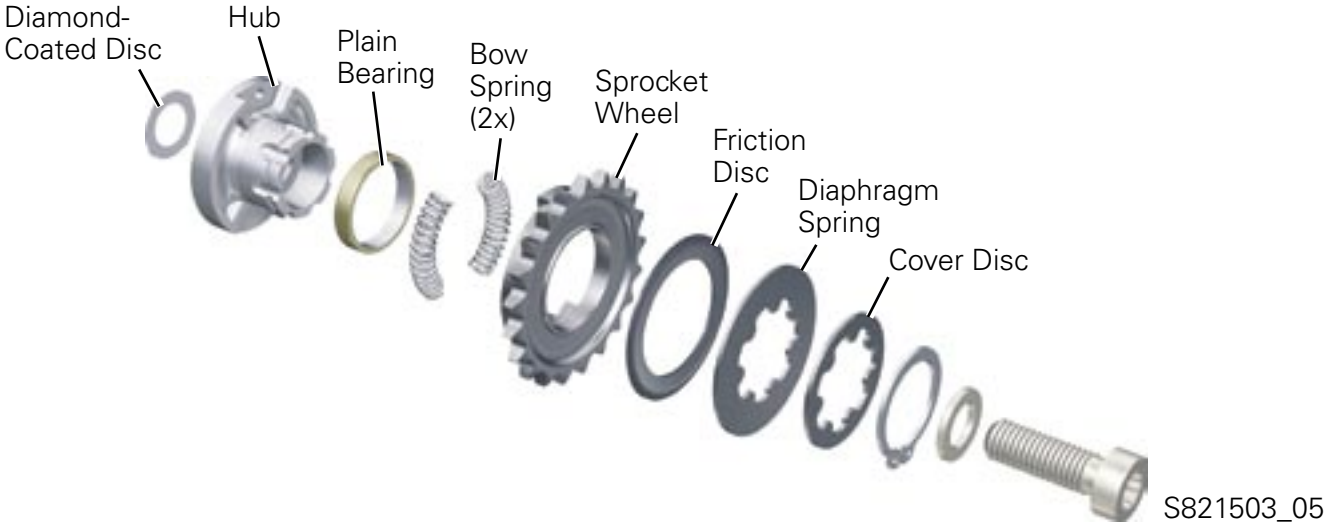

S821503\_05

# Engine Mechanics

---

## Toothed Belt Drive

The toothed belt drive system is designed to meet turbocharging demands using:

- High valve spring pressures
- Turbo-related valve timing associated with the  $42^\circ$  crank angle adjustment range of the continuous variable valve timing on the intake camshaft
- High-pressure oil pump drive from a triple cam on the intake camshaft

As a result of these demands, an elliptical toothed belt sprocket was developed. The Crankshaft Torsional Cancellation (CTC) toothed belt sprocket reduces camshaft vibration and the forces acting on the toothed belt.

### Function

The toothed belt drive sprocket is positioned on the crankshaft at TDC of cylinder 1, as shown below. When the cycle begins, forces acting on the toothed belt are reduced by the elliptical shape of the toothed belt sprocket. The flat side of the sprocket gear allows a slight slackening of the toothed belt. This slackening helps to reduce wear on the toothed belt, improving reliability and extending replacement intervals.

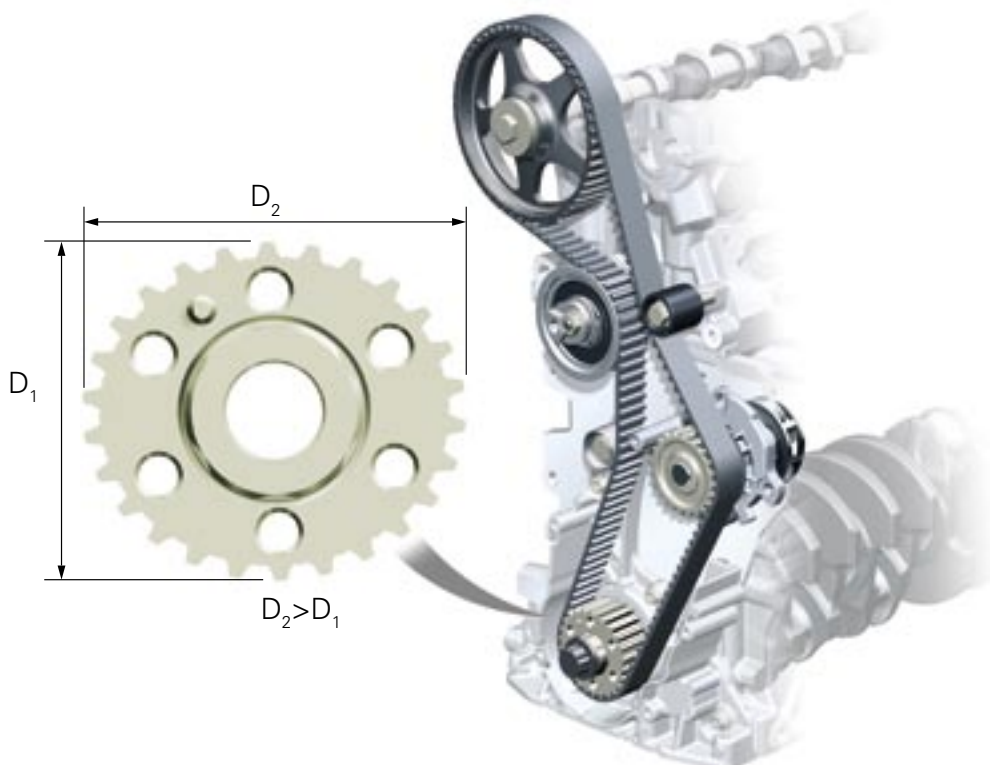

S821503\_06

## Cylinder Head

The cylinder head of the 2.0L FSI turbocharged engine incorporates the following features:

- Sodium-filled exhaust valves
- Reinforced intake valve seat
- Roller rocker fingers that reduce the land width of the camshaft and roller
- Identical high tension valve springs for both intake and exhaust valves

The geometry of the intake port reduces knock and improves running smoothness.

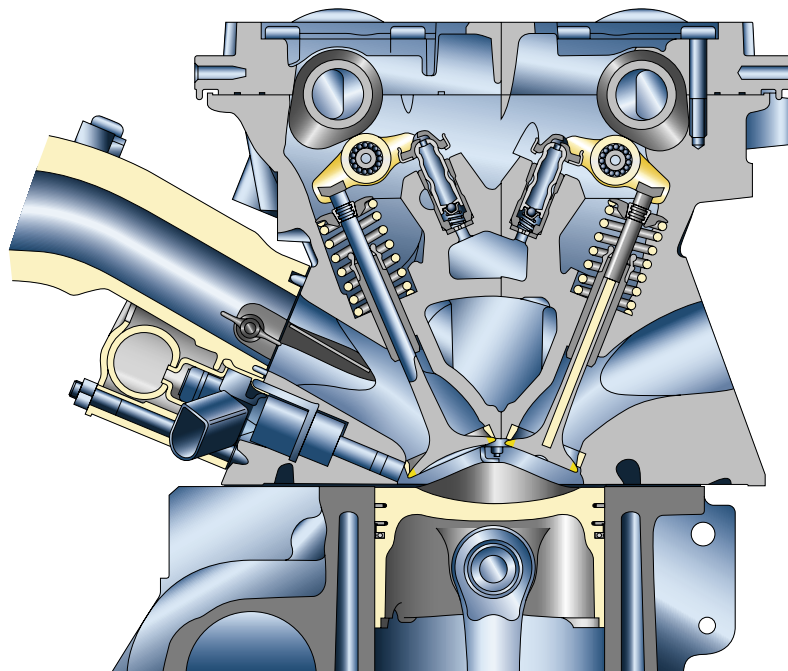

337\_016

# Engine Mechanics

---

## Crankcase Ventilation

The crankcase is maintained in a constant vacuum while the engine is running. The crankcase breather that supplies this vacuum is connected to the intake manifold.

The crankcase blow-by gases are separated in two stages. In the first stage, the primary oil separator in the oil filter module takes most of the oil out of the gases. A second separator in the cylinder head cover removes the remainder of the oil from the gases.

Since a turbo engine requires a more sophisticated pressure control system, a two-stage pressure control valve is located on the cylinder head cover. If vacuum exists in the intake manifold, blow-by gases flow directly into the intake manifold.

If a boost pressure is present in the intake manifold, a one-way valve in the pressure control valve housing closes and the blow-by gases flow into the cylinder head cover ahead of the turbocharger. The system can detect faulty installation of the pressure control valve. Unmetered air is detected by the reaction of the oxygen sensor.

# Engine Mechanics

- If a boost pressure is present upstream of turbocharger
- If a vacuum is present in the intake manifold

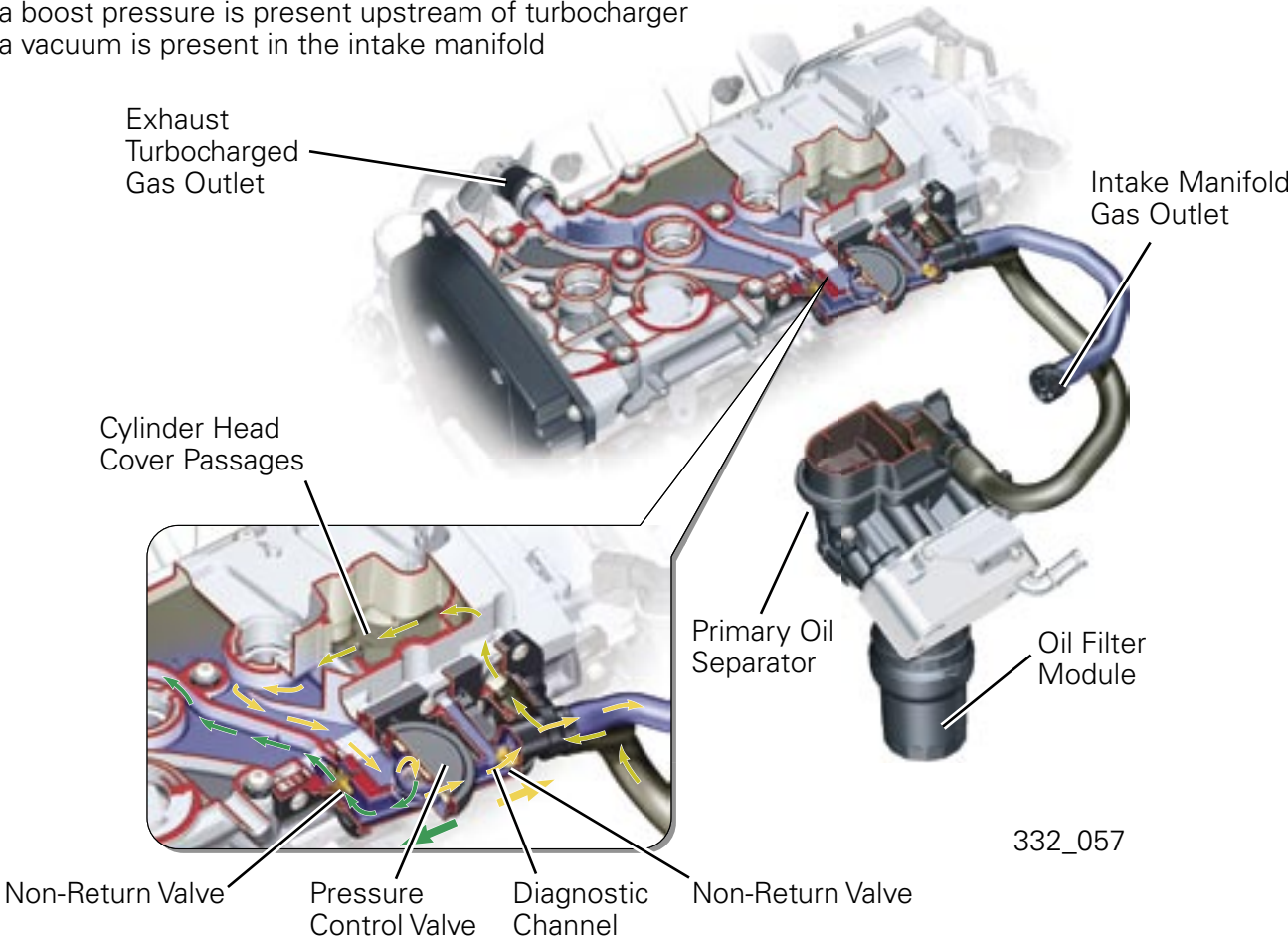

# Engine Mechanics

---

## Exhaust Turbocharger/Manifold Module

To conserve space and improve performance and serviceability, the exhaust manifold and turbine housing have been combined into a single module. Special emphasis was placed on easy removal and installation of the exhaust manifold and the close-coupled catalytic converter.

The turbine shaft mount is integrated into the compressor housing. The air intake includes connections for crankcase and Evaporative Emission (EVAP) Canister Purge Regulator Valve N80. A silencer reduces pressure pulsation noises.

Boost pressure is controlled by a Wastegate Bypass Regulator Valve N75. A Turbocharger Recirculating Valve N249 keeps a portion of air running through the intake side of the turbocharger when the throttle valve is closed and boost pressure is still present. This keeps the turbocharger impeller from slowing down, reducing turbo lag when the throttle is applied again. The Wastegate Bypass Regulator Valve N75 and the Turbocharger Recirculating Valve N249 are located on the turbocharger.

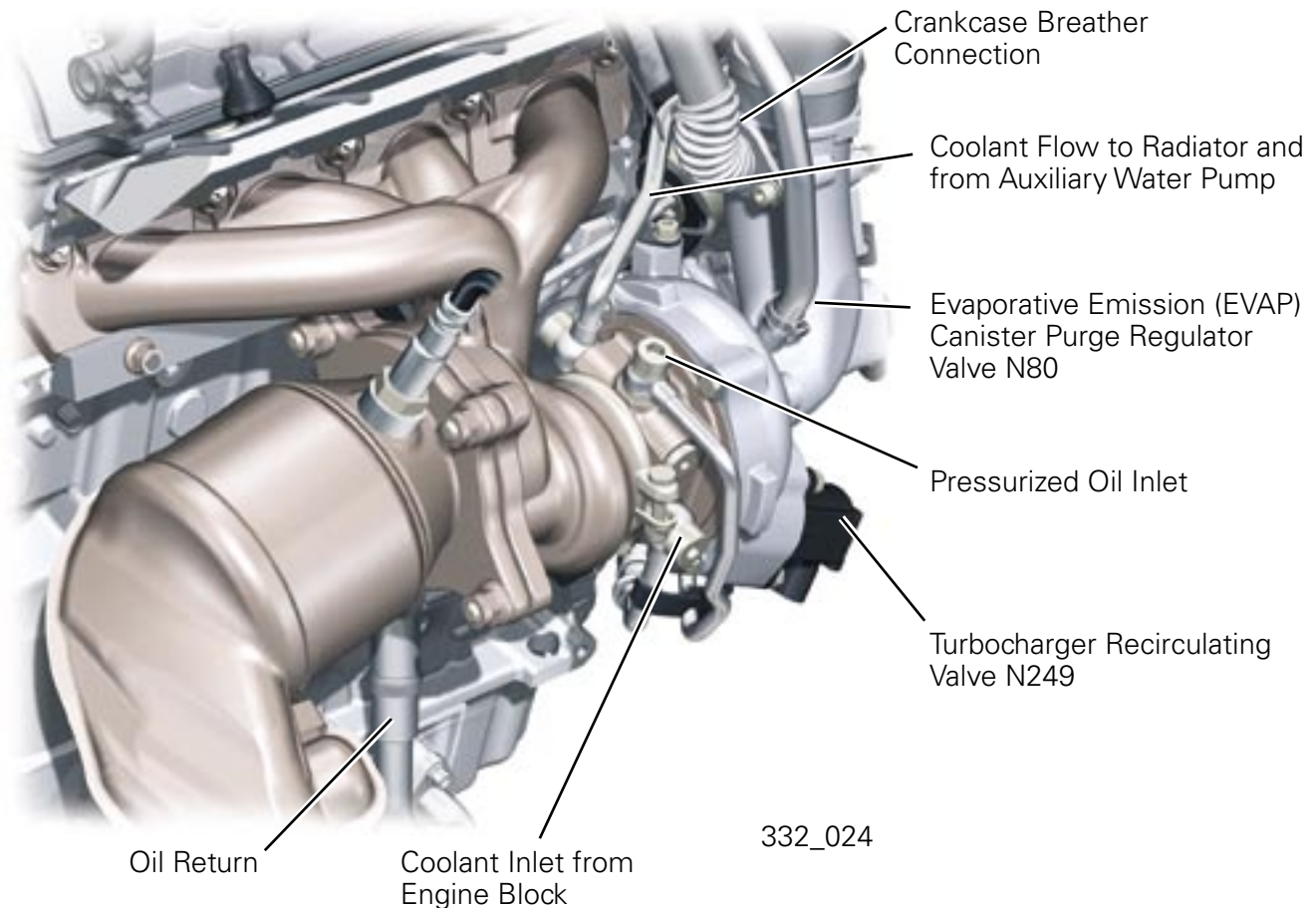

A clamping flange on the cylinder head allows easy removal and installation of the exhaust turbocharger/manifold module. The clamping flange does not require removal.

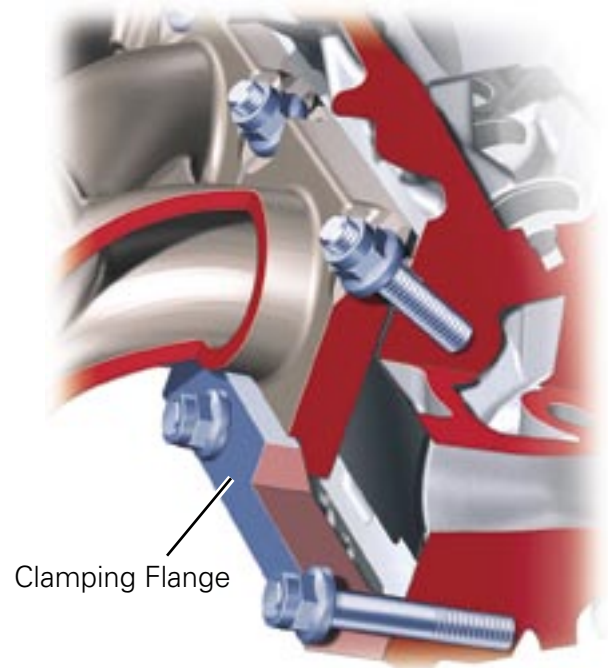

332\_025

The exhaust manifold is split. A divider in the manifold ensures a steady flow of exhaust gases to the turbine. The ports of cylinders 1 and 4 and cylinders 2 and 3 are separated based on the firing order. The divider also prevents the exhaust gas pressure from expanding into the other cylinders.

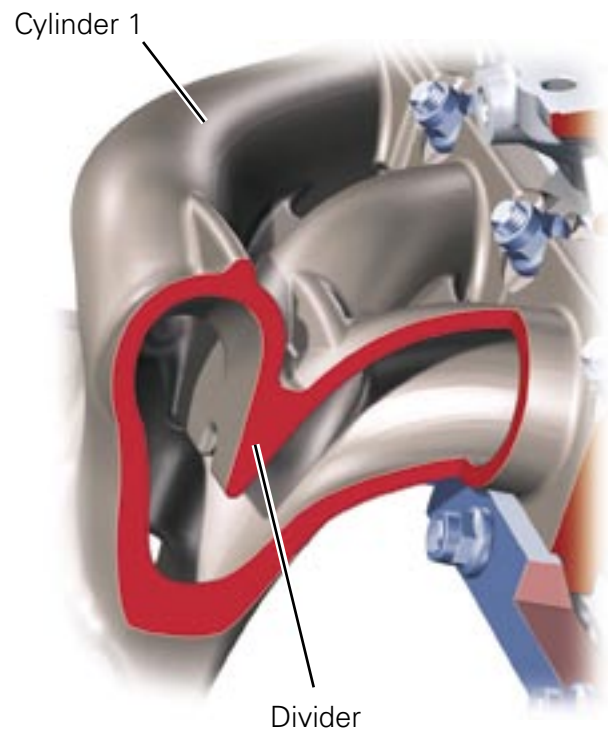

332\_026

# Engine Mechanics

## Charge Air Ducting and Boost Pressure Control

Both the boost and intake pressures are used to control the wastegate of the turbocharger. These pressure signals are supplied to the ECM, which then sends a pulse-width modulated signal to the Wastegate Bypass Regulator Valve N75. As a result N75 controls vacuum supply to the Pressure Unit, which directly acts on the wastegate via a connecting rod. This control system regulates the turbine speed and sets the maximum boost pressure.



If the control system fails, the boost pressure acts directly on the pressure unit. The increased spring pressure reduces maximum boost down to minimum boost.

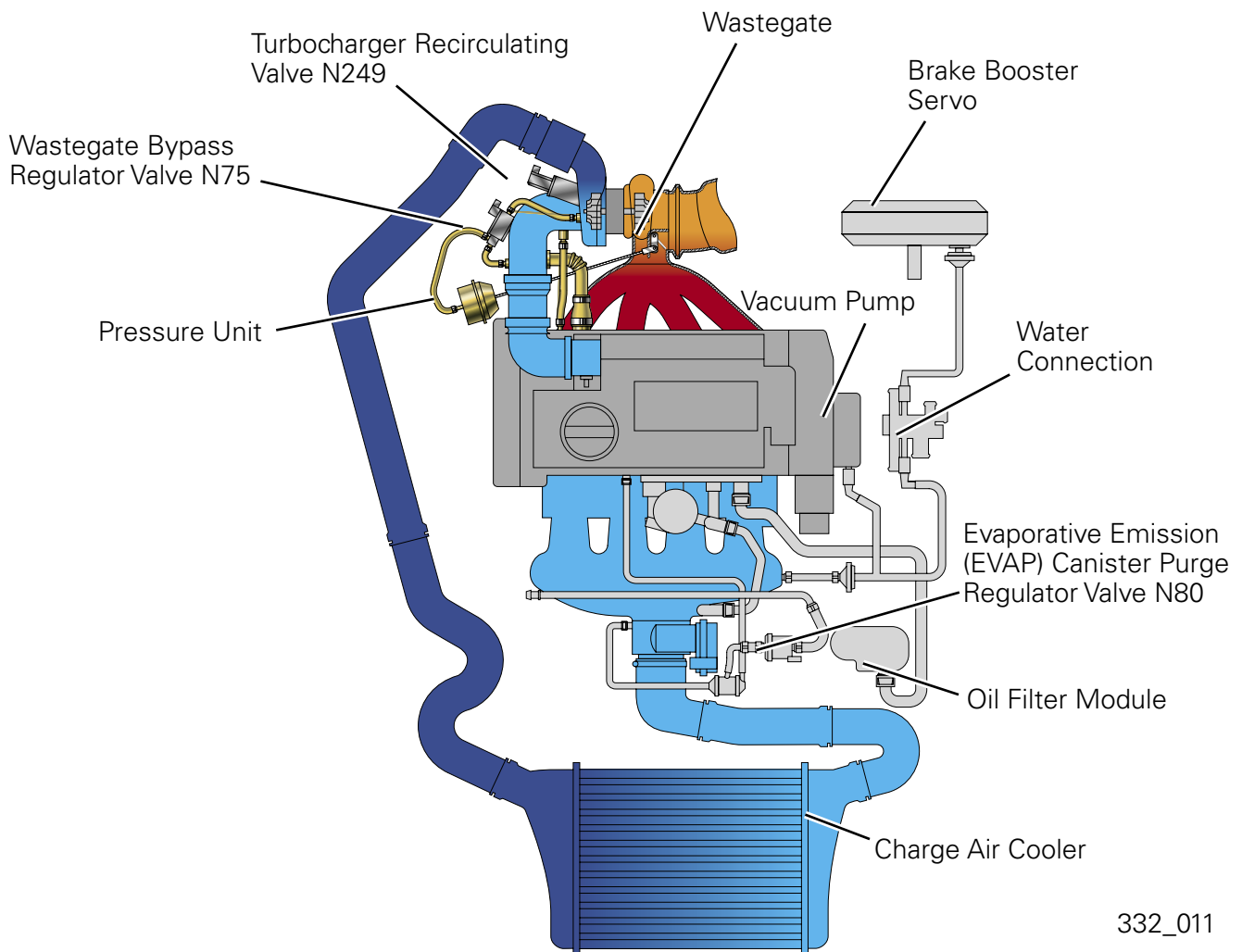

332\_011



## Boost Pressure Overrun

If the throttle valve closes when the engine is in overrun, back pressure develops in the turbo housing. Back pressure reduces the speed of the turbine, which reduces boost pressure and increases turbo lag when the engine accelerates again.

At other engine speeds, the tumble flaps are open to eliminate flow resistance and reduction in engine performance.

To avoid this, the Turbocharger Recirculating Valve N249 is opened by an electrical actuator. This allows the compressed air to flow back to the intake side of the circuit through the turbine. This maintains turbine speed. The Turbocharger Recirculating Valve N249 closes when the throttle valve opens again and boost pressure is immediately available.

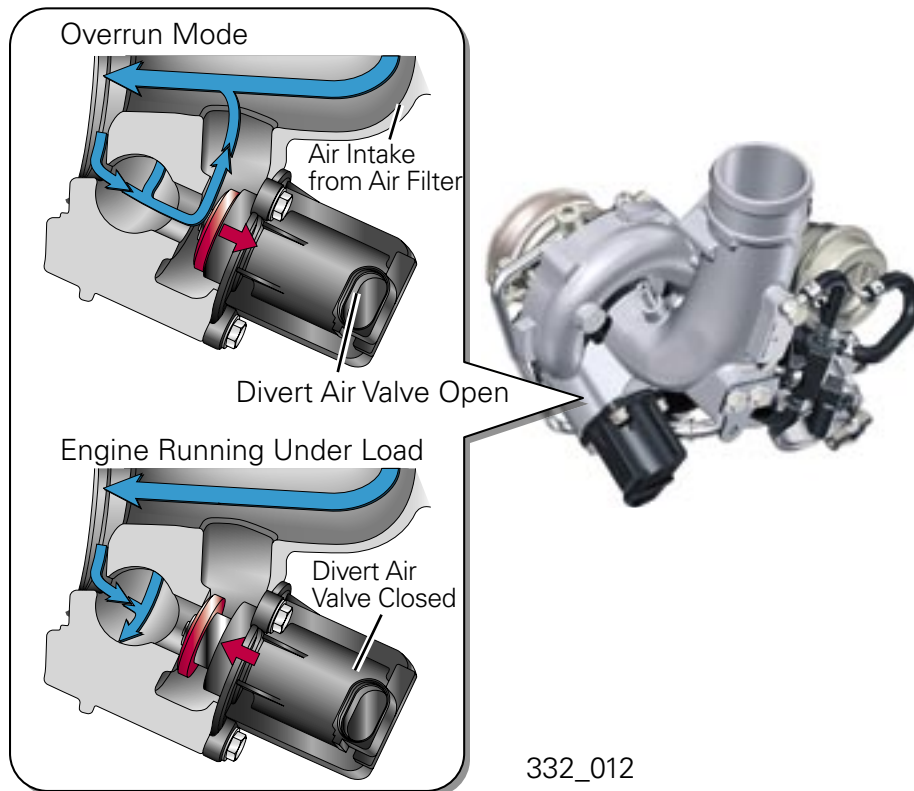

# Engine Mechanics

## Cooling System

To prevent carbon build-up on the turbine shaft in the turbocharger, an auxiliary coolant pump provides additional coolant circulation for a certain time after the engine is shut off hot. The pump forces the lower temperature coolant against the normal direction of flow. The coolant flows from the radiator through the turbocharger to the engine block and back to the cooler.

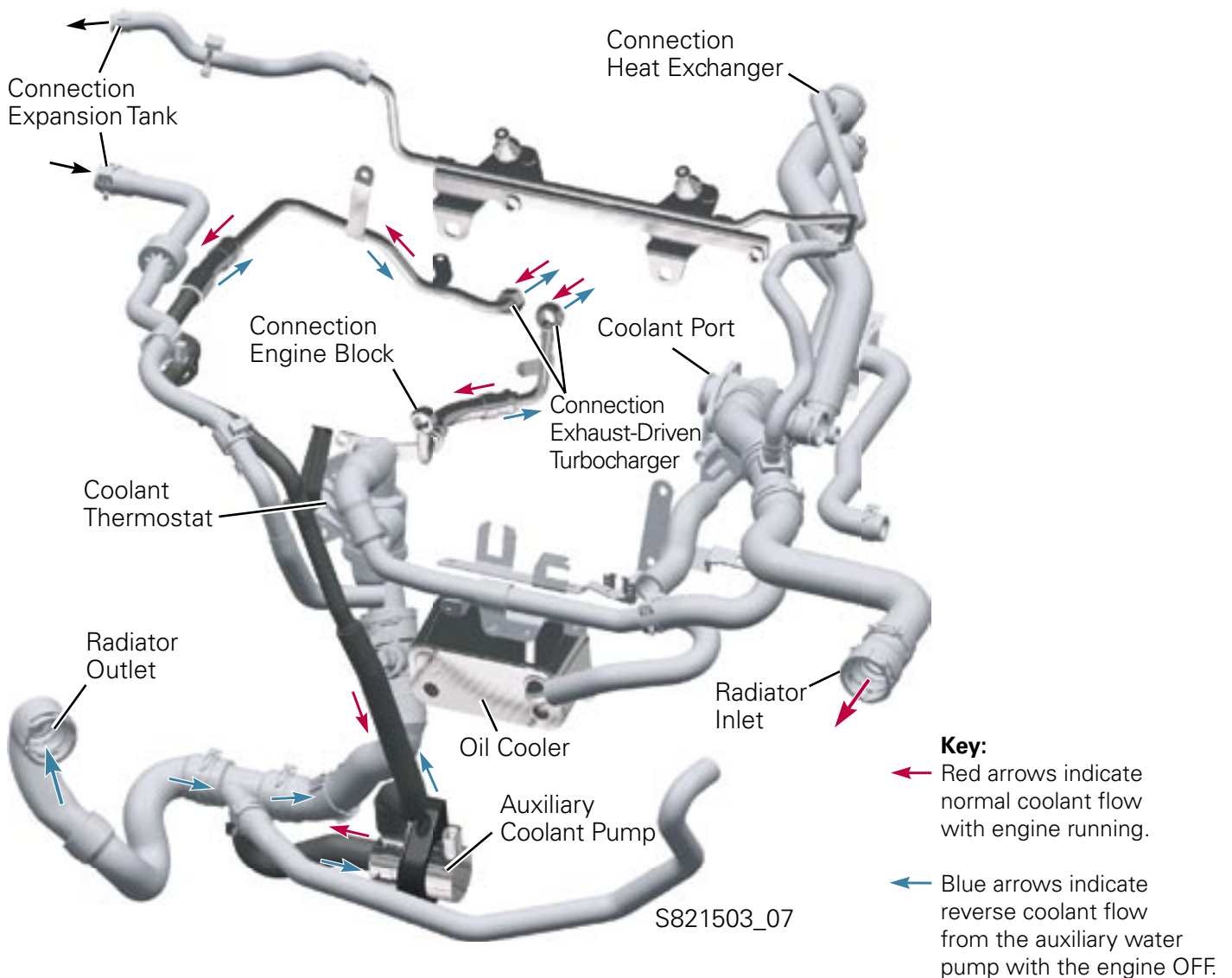

## Tumble Flaps

Tumble flaps are individual plates located within the intake manifold runners that can either stay in a flat position to allow maximum airflow or move up to redirect the airflow into the combustion chamber. At different engine rpms, the tumble flaps are activated to enhance the air/fuel mixture.

The tumble flaps are actuated:

- To improve cold engine idling
- To improve charge efficiency at start-up
- In overrun mode

At other engine speeds, the tumble flaps are open to eliminate flow resistance and reduction in engine performance.

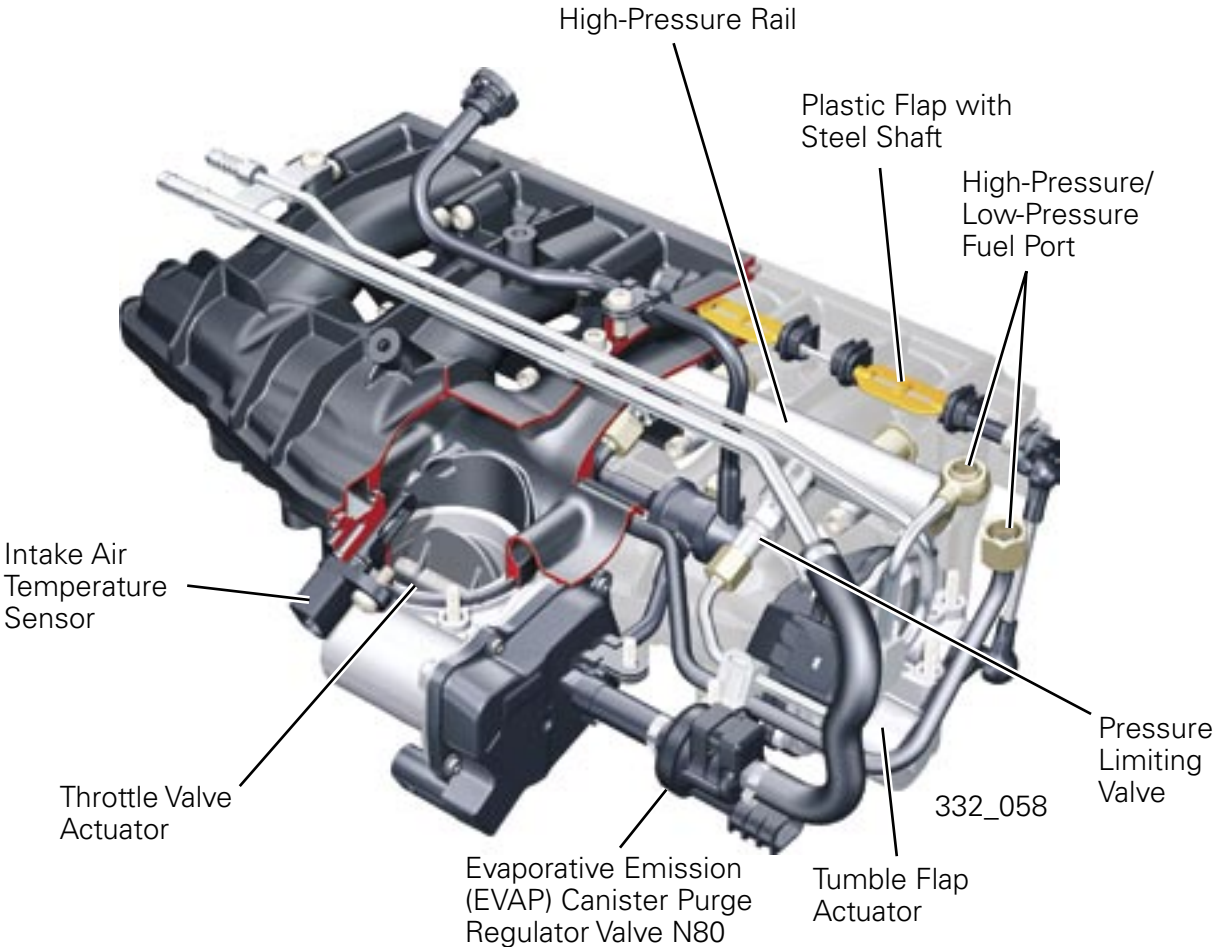
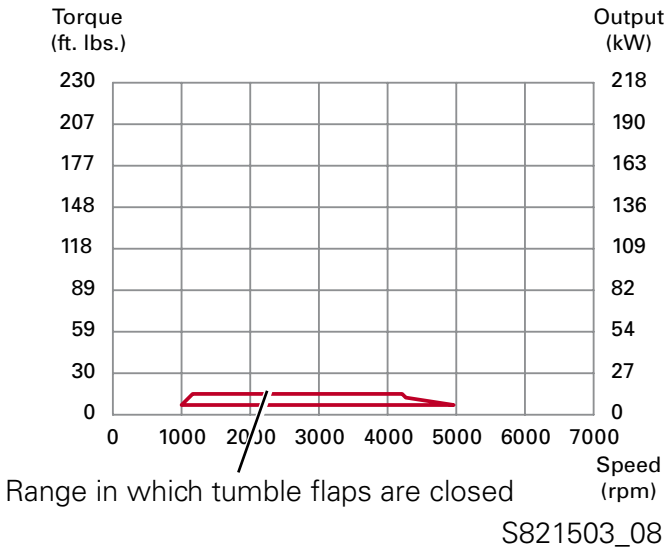

# Fuel System Overview

## Demand-Controlled Fuel System

The demand-controlled fuel system combines the advantages of the low pressure electric fuel pump with the high pressure fuel pump by providing only as much fuel as the engine needs at any given time. This reduces the electrical and mechanical power requirements of the fuel pumps and saves fuel.

The fuel system is divided into low pressure and high pressure systems.

### Low Pressure System

The low pressure system maintains fuel pressure in the 7.3–72.5 psi (0.5–5 bar) range.

The pressure is increased to 94.3 psi (6.5 bar) for hot and cold engine startup.

Increasing low pressure results in higher pressure in the high pressure system for cold starts. It achieves better mixture preparation and a quicker start.

The pressure increase also prevents the formation of vapor bubbles in the high pressure fuel pump for hot starts.

### Low Pressure System Components Include:

- Fuel Pump Control Module J538
- Fuel tank
- Transfer Fuel Pump G6
- Fuel filter with pressure limiting valve (opens at approximately 98.6 psi [6.8 bar])
- Low Fuel Pressure Sensor G410

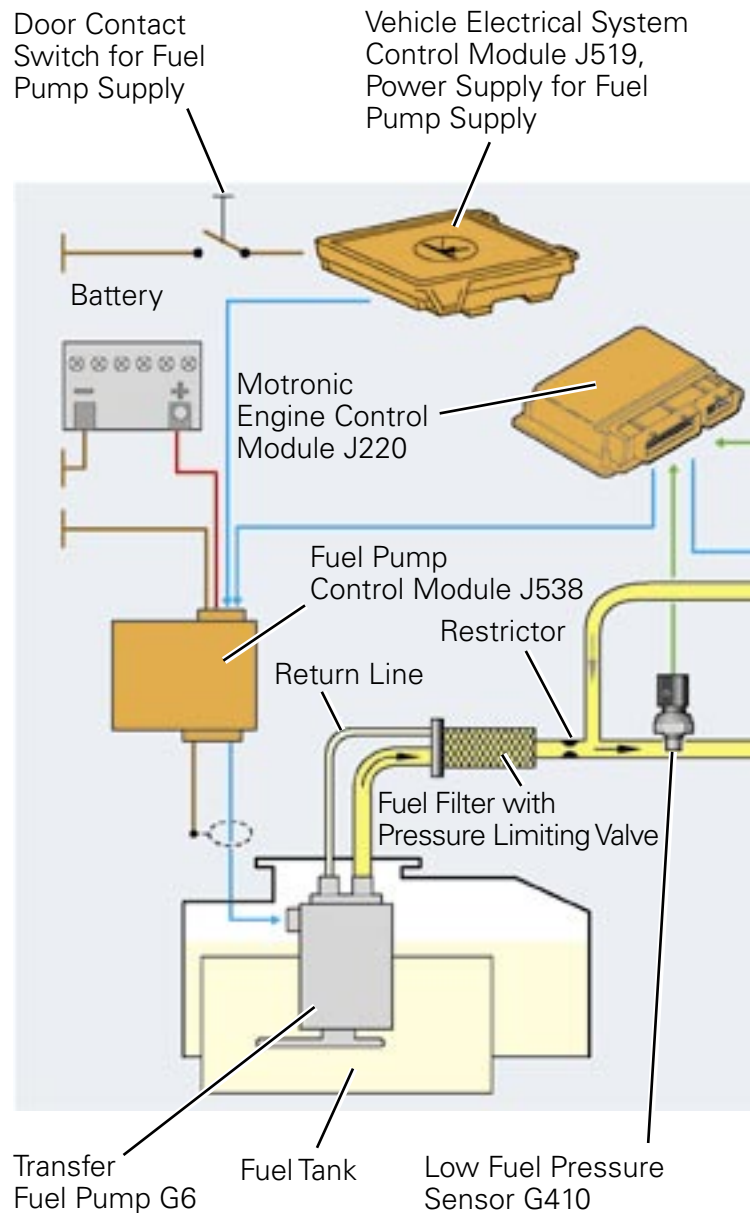

### Key

	No pressure		Low pressure fuel system
	Low pressure		High pressure fuel system
	High pressure		

# Fuel System Overview

## High Pressure System

The high pressure system maintains fuel pressure in the 435–1,595 psi (30–110 bar) range. The pressure range may vary.



**Important:** Before opening the system, the excess pressure must be bled off. The high pressures of this fuel system can cause injury or death. Always reference the electronic service repair information.

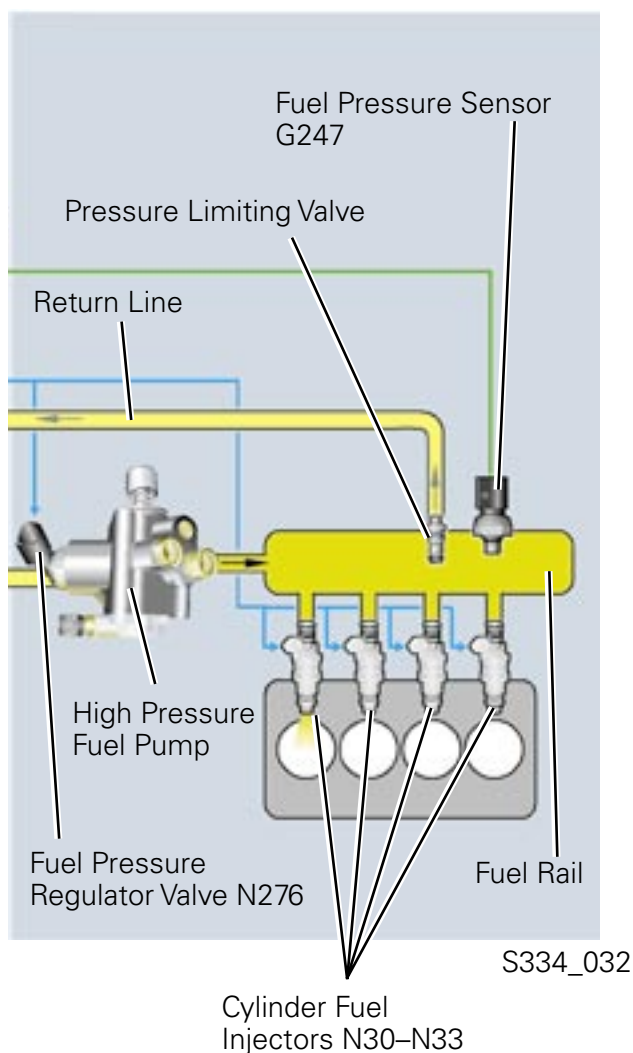

## High Pressure System Components Include:

- High pressure fuel pump
- Fuel Pressure Regulator Valve N276
- Fuel rail
- Pressure limiting valve (opens at approximately 1,740 psi [120 bar])
- Fuel Pressure Sensor G247
- Cylinder Fuel Injectors N30-N33

# Fuel System Components

---

## Fuel Pump Control Module J538

The Fuel Pump Control Module J538 is located in the electric fuel pump cover.

### Function

The Fuel Pump Control Module J538 controls the Transfer Fuel Pump G6 by means of a pulse-width modulated signal (PWM). The control module regulates pressure in the low pressure fuel system from 7.3–72.5 psi (0.5–5 bar).

The pressure is increased to 94.3 psi (6.5 bar) during hot or cold startups.

### Failure Strategies

If the Fuel Pump Control Module fails, the engine will not start or run.

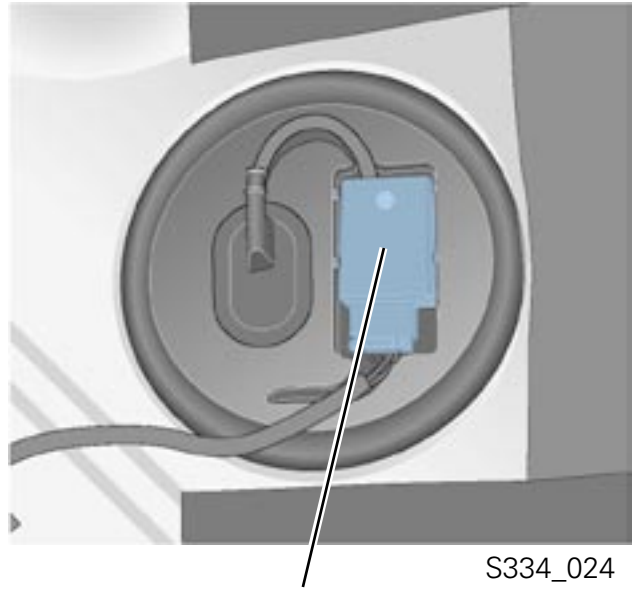

Fuel Pump Control Module J538

## Transfer Fuel Pump G6

The Transfer Fuel Pump G6 is integrated with the fuel level sensor. This unit is mounted in the fuel tank.

### Function

G6 provides fuel, through the low pressure fuel system, to the high pressure fuel pump.

G6 is regulated by a PWM signal from J538.



S334\_076

# Fuel System Components

## System Operation

The Transfer Fuel Pump G6 only provides the required amount of fuel to the engine.

Low-Side Fuel pressure is constantly measured by the Low Fuel Pressure Sensor G410 and sent to the Motronic Engine Control Module (ECM) J220. If this pressure deviates from the reference pressure, J220 sends a PWM signal (20 Hz) to the Fuel Pump (FP) Control Module J538. J538 then sends a PWM signal (20 kHz) to the Transfer Fuel Pump G6 until the desired fuel pressure is achieved.

## Advantages

- Less power used because the fuel pump only provides the amount of fuel required by the engine
- Lower fuel temperature because only as much fuel is compressed as is required by the engine
- Lower noise levels, especially at idle

## Failure Strategies

If the Transfer Fuel Pump G6 fails, the engine will not run.

## Low Pressure System

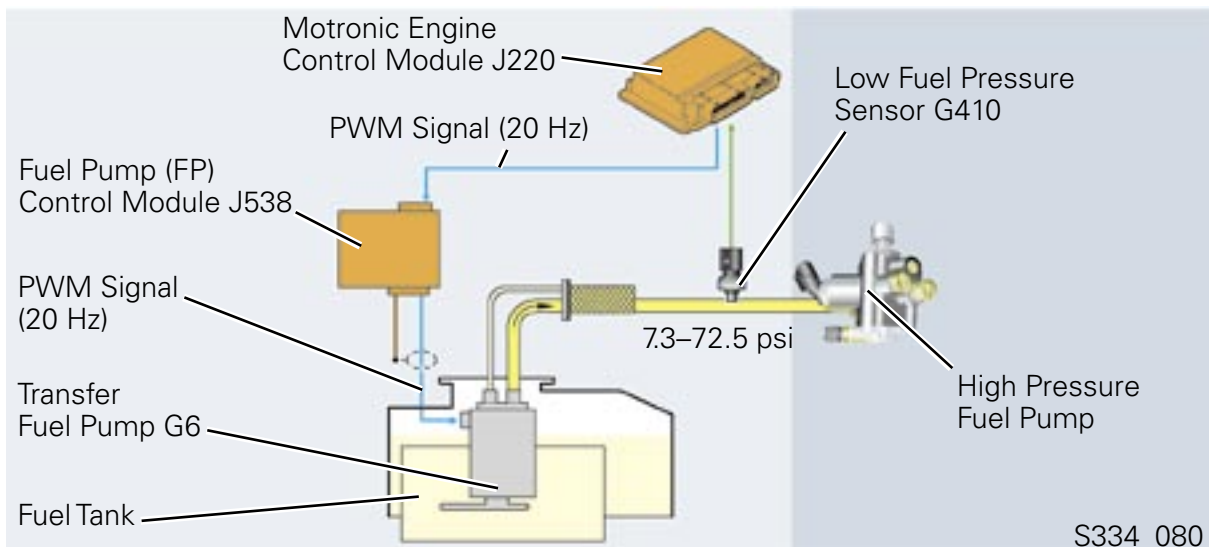

If either the Motronic Engine Control Module J220 or the Fuel Pump (FP) Control Module J538 is replaced, reference the messages displayed during "Guided fault finding" on the VAS 5051 to perform the adapt procedure.

# Fuel System Components

---

## High Pressure Fuel Pump with Fuel Pressure Regulator Valve N276

The high pressure fuel pump is mounted on the cylinder head. This pump provides between 450 and 1,595 psi (31 and 110 bar) to the fuel rail.

### Unique Features

- The pump is a volume-controlled, single-cylinder, high pressure fuel pump that pumps only as much fuel into the fuel rail as is required for fuel injection. This reduces its output requirements and saves fuel
- There is no return line on the high pressure fuel pump. Excess fuel flows back to the low pressure side of the supply line

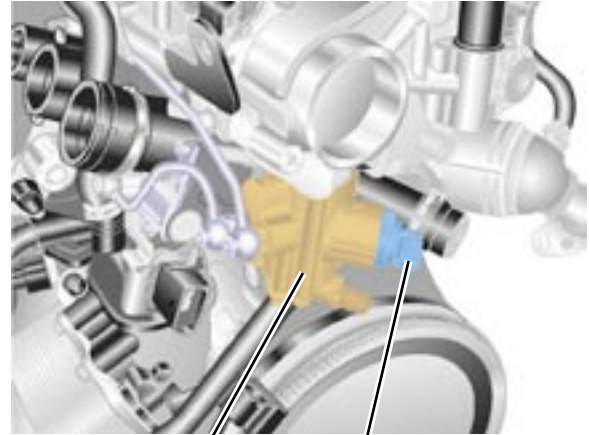

High Pressure Fuel Pump

Fuel Pressure Regulator Valve N276

S334\_018

## High Pressure Fuel Pump Drive

The high pressure fuel pump is driven by a double cam on the end of the intake camshaft.



**Important:** Before opening the system, the excess pressure must be bled off. The high pressures of this fuel system can cause injury or death. Always reference the electronic service repair information.

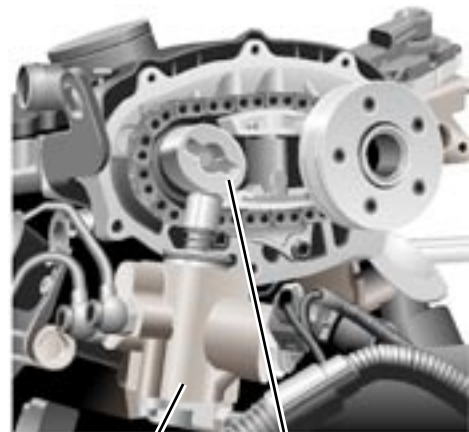

High Pressure Fuel Pump

Double Cam

S334\_068



# Fuel System Components

---

## High Pressure Fuel Pump

Both fuel lines are metal and are threaded to the pump.

The cover cap includes a vent valve that is only required in production.

The fuel system is vented during operation by the injectors.



The high pressure fuel pump is not serviceable. If the pump fails, replace it as a unit.

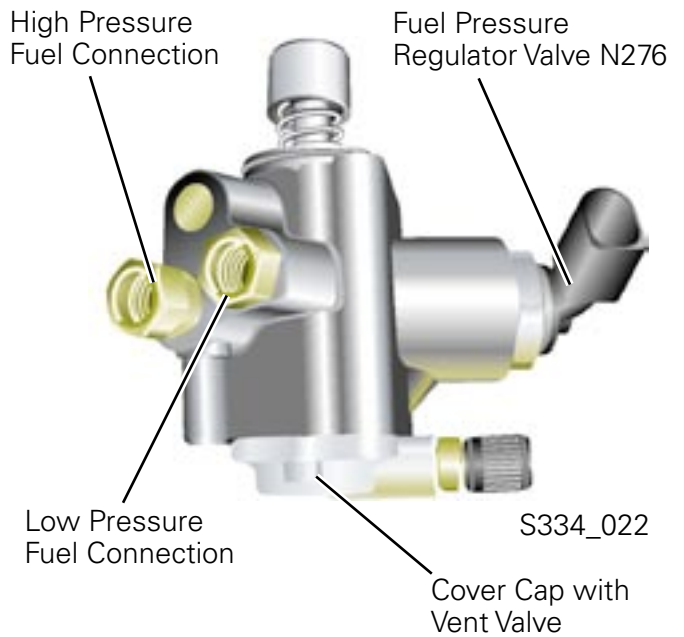

# Fuel System Components

## High Pressure Fuel Pump Operation

The high pressure fuel pump is a volume-controlled, single-cylinder, high pressure pump. It is map-controlled, and pumps only as much fuel as is required for injection.

The engine control module calculates the start of the delivery stroke from the required injection amount.

When the time is right, the fuel pressure regulating valve closes the inlet valve and the delivery stroke begins.

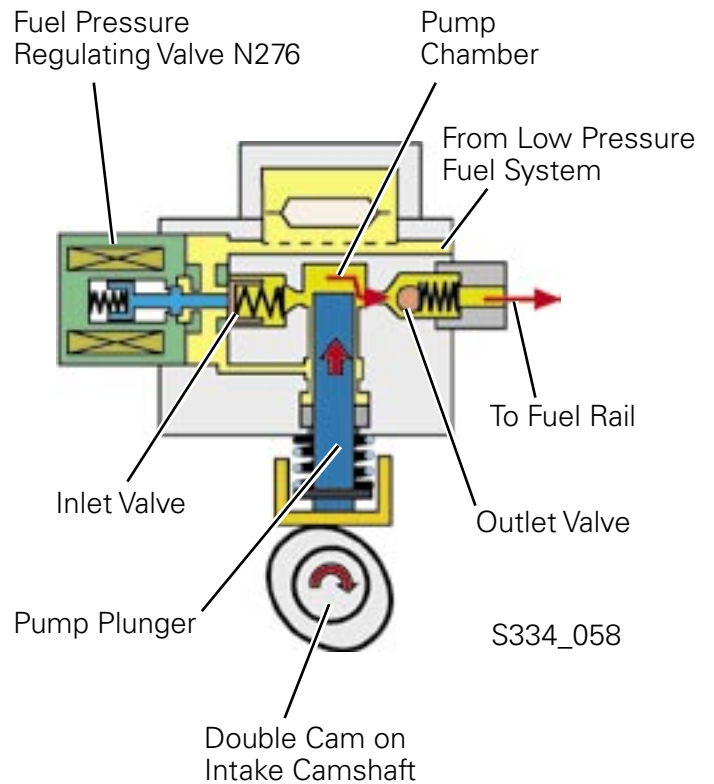

The chart is divided into three parts representing the pump's intake stroke, return stroke and delivery stroke.

The appropriate stroke section of the chart is shaded.

- The blue line indicates the curve of the cam during the rising or falling of the pump plunger
- The red line indicates the pressure in the pump chamber

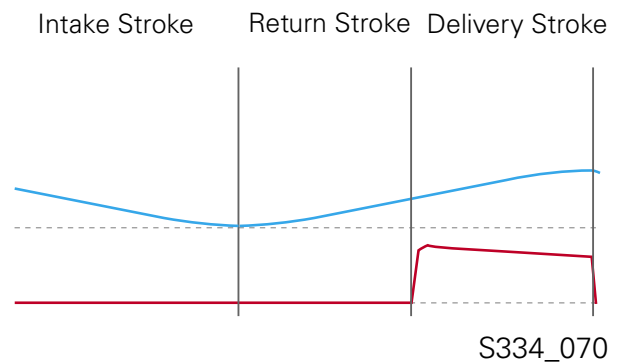

# Fuel System Components

## Intake Stroke

During the pump intake stroke, the valve needle spring forces the valve needle to open the inlet valve.

Fuel is drawn into the pump chamber by the downward movement of the pump plunger.

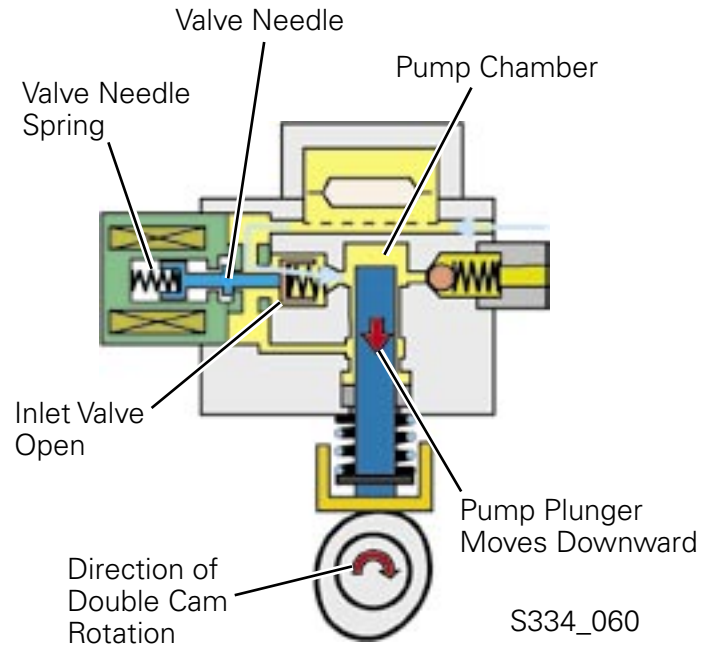

## Intake Stroke Operation

- The pump plunger moves down
- The pressure in the pump chamber is approximately the same as the pressure in the low pressure fuel system

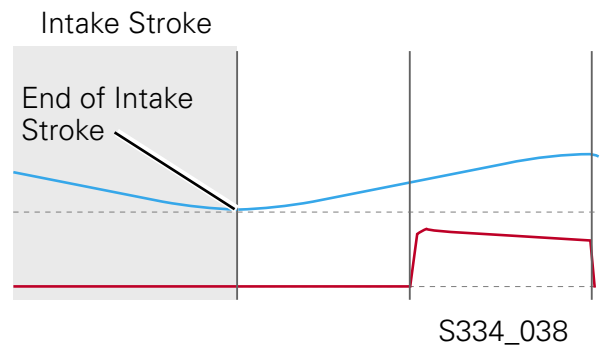

# Fuel System Components

## Return Stroke

The inlet valve remains open as the pump plunger begins to move upward. This allows the fuel quantity to adjust to actual consumption. The pump plunger forces excess fuel back into the low pressure system.

The resulting pressure pulses are dampened by the fuel-pressure attenuator and a restrictor located in the fuel supply line.

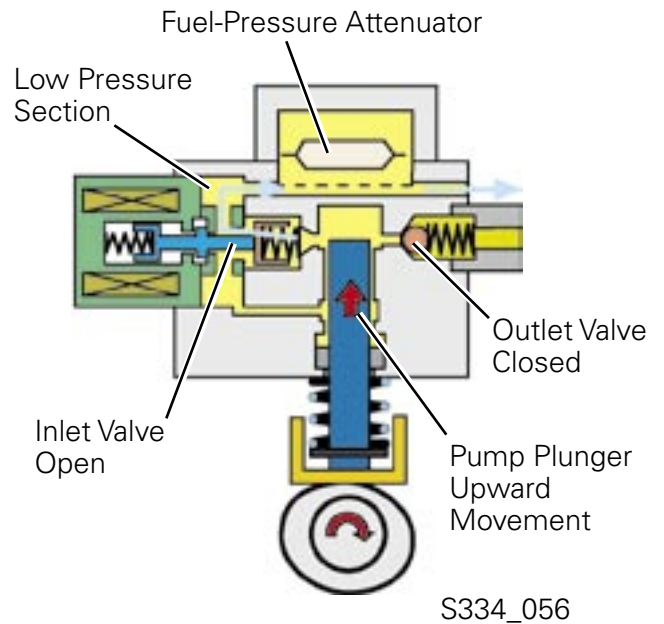

## Return Stroke Operation

- The pump plunger begins its upward stroke with the inlet valve remaining open. Pressure in the pump chamber is approximately the same pressure as the low pressure fuel system

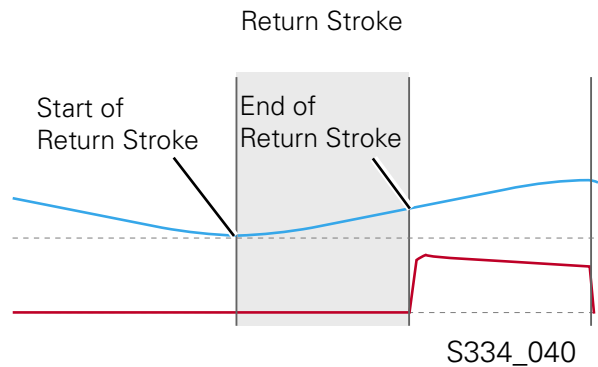

# Fuel System Components

## Delivery Stroke

At the beginning of the delivery stroke the fuel pressure regulating valve is briefly energized to force the valve needle back against the force of the valve needle spring, allowing the inlet valve to be closed by the force of the inlet valve spring. Pressure builds in the pump chamber as the pump plunger moves upward. When the pressure in the pump chamber is higher than the pressure in the fuel rail, the outlet valve opens and fuel is forced into the fuel rail.

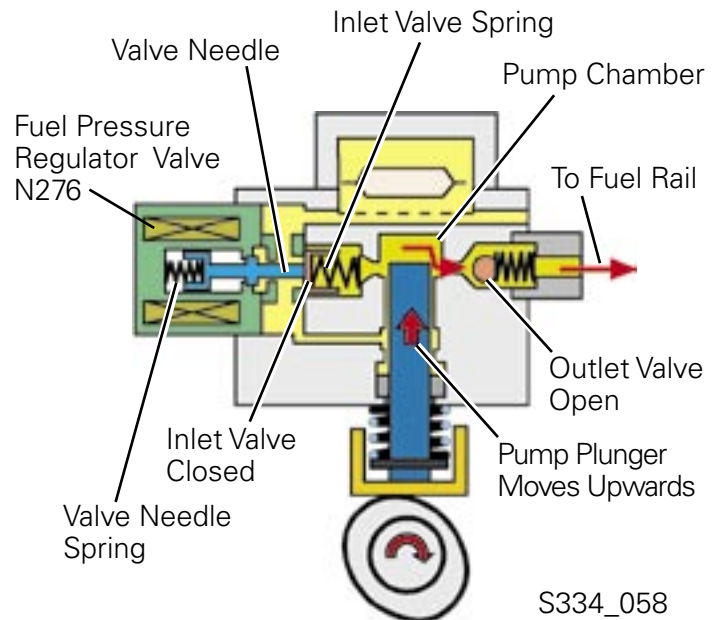

## Delivery Stroke Operation

- The pump plunger continues its upward stroke
- Pressure in the pump chamber increases. Pump pressure starts to fall when the pump plunger reaches its highest point. This is the end of the delivery stroke

The start of the delivery stroke varies depending on the amount of fuel required.

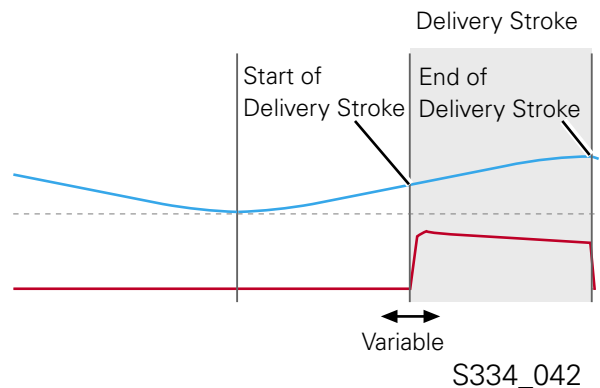

# Fuel System Components

---

## Low Fuel Pressure Sensor G410

The Low Fuel Pressure Sensor G410 is located in the high pressure fuel pump supply line. The sensor measures fuel pressure in the low pressure fuel system and sends a signal to the engine control module.

### Signal Function

The engine control module uses the signal from the Low Fuel Pressure Sensor G410 to regulate pressure in the low pressure fuel system.

The fuel pressure ranges from 7.3–72.5 psi (0.5–5 bar) depending on the engine.

### Failure Mode

If the Low Fuel Pressure Sensor G410 fails, a fixed PWM signal activates the Transfer Fuel Pump G6 to increase pressure in the low pressure system.

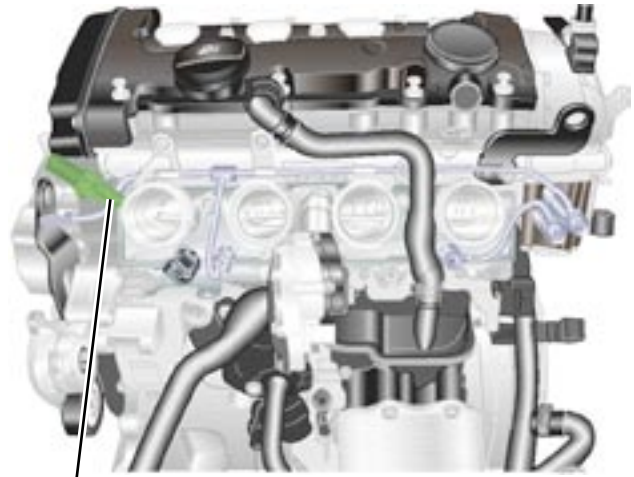

S334\_012

Low Fuel Pressure  
Sensor G410

# Fuel System Components

---

## Fuel Pressure Sensor G247

The Fuel Pressure Sensor G247 for the high pressure system is located on the lower part of the intake manifold in the fuel rail.

The sensor measures fuel pressure in the fuel rail and sends a signal to the engine control module.

### Signal Function

The engine control module uses the signal from the Fuel Pressure Sensor G247 to regulate pressure in the fuel rail via the fuel pressure regulating valve. The fuel pressure may range from 435–1,595 psi (30–110 bar) depending on the engine.

### Failure Mode

If the Fuel Pressure Sensor G247 fails, the Engine Control Module J220 sets the Fuel Pressure Regulating Valve N276 at a predetermined fixed pressure.



Fuel Pressure Sensor G247,  
High Pressure System

S334\_014

# Fuel System Components

## Cylinder Fuel Injectors N30–N33

The high-pressure fuel injectors are mounted in the cylinder head and inject high-pressure fuel directly into each combustion chamber.

### Fuel Injector Function

The fuel injectors spray atomized fuel directly into the combustion chamber.

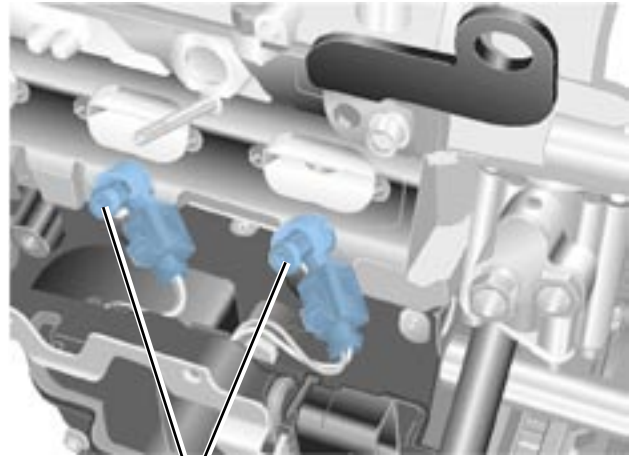

S334\_054

High-Pressure  
Fuel Injectors



Special tools are required for installation of the injector seals. Please reference the latest service information.

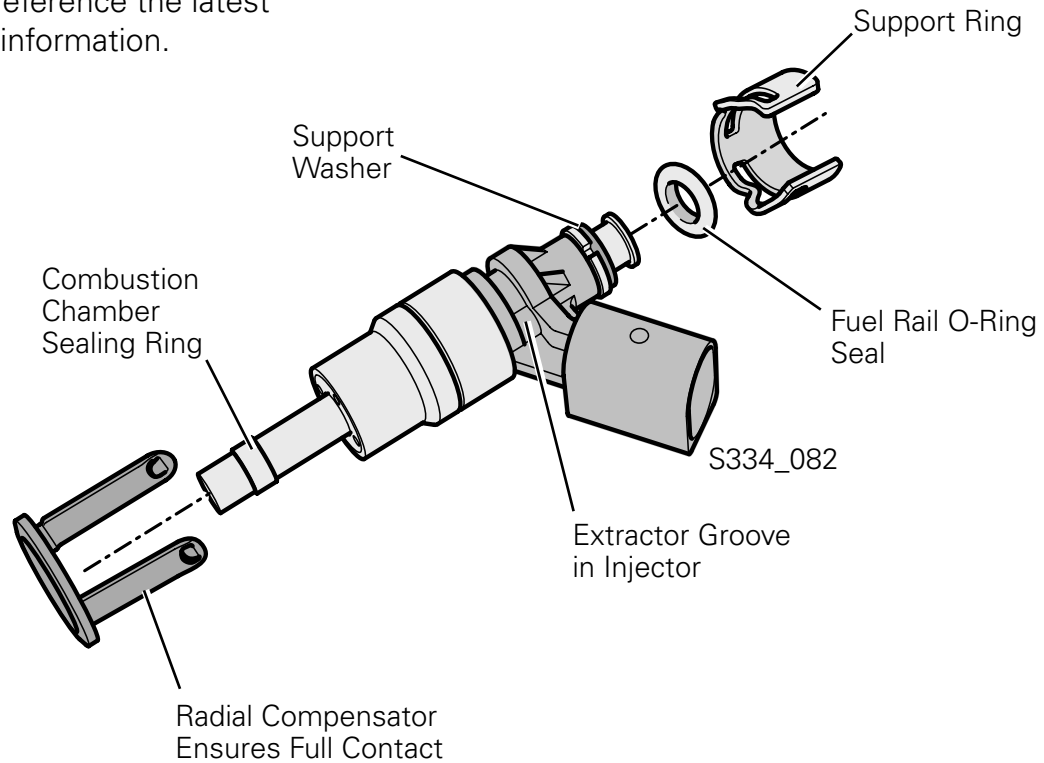



# Fuel System Components

---

## Fuel Injector Operation

During fuel injection, the injector's solenoid is activated producing a magnetic field. This energizes the solenoid armature's valve needle opening the valve, injecting fuel.

When activation stops, the magnetic field collapses and the valve needle is forced back into the valve seat by the compression spring stopping fuel flow.

## Failure Strategy

If a defective fuel injector is detected by the misfire detection circuit, that fuel injector is deactivated.

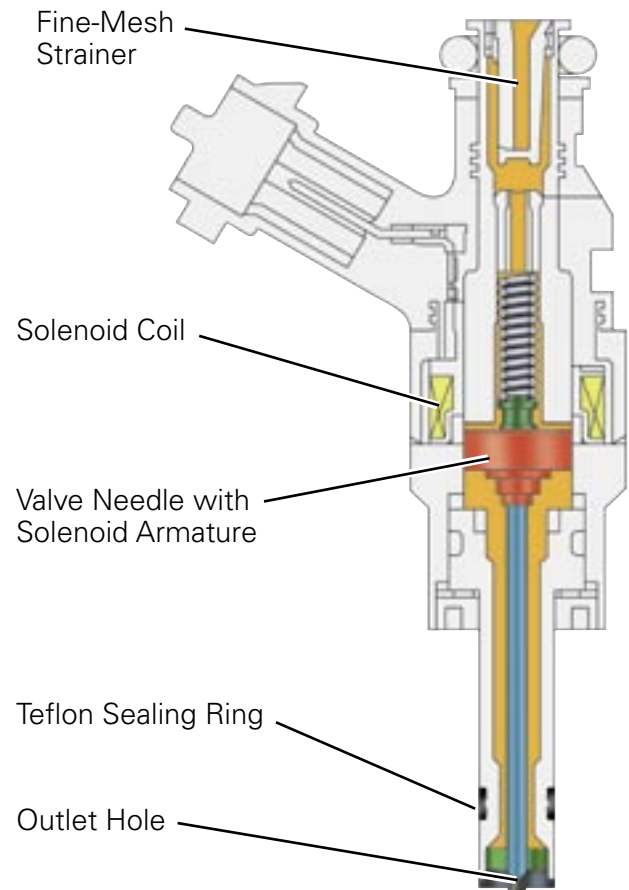

S334\_083

# Fuel System Components

## Pressure Limiting Valve

The pressure limiting valve is mounted in the fuel rail and protects components from damage caused by excessive fuel pressure.

The pressure limiting valve is mechanical and only opens at fuel pressures above 1,740 psi (120 bar). The valve releases fuel from the fuel rail via the return line to the fuel supply line. There the fuel is directed back to the high-pressure fuel pump.

The short return line on the engine eliminates the long return line that runs to the fuel tank.

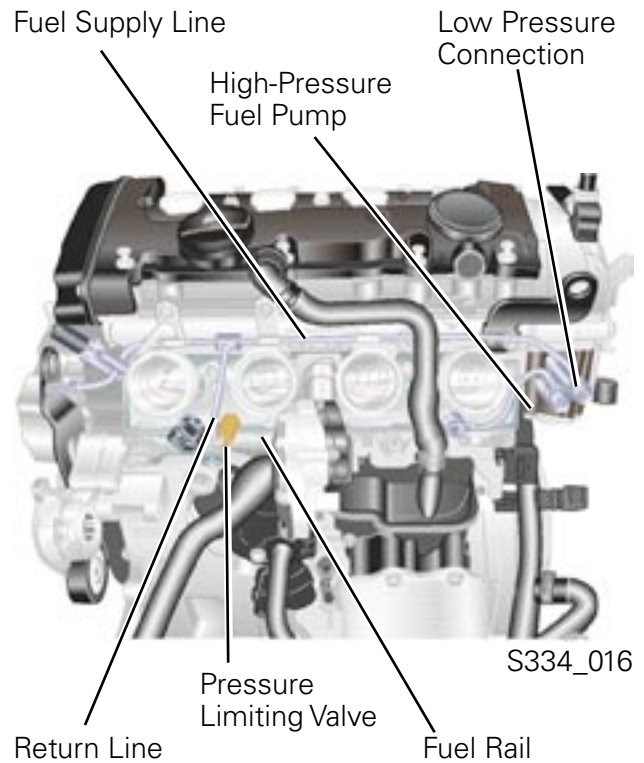

## Connector Fitting with Restrictor

The connector fitting is located between the fuel supply line and the return line and includes a 0.06 in. (1.5mm) diameter restrictor.

The connector fitting with restrictor ensures that:

- The high fuel pressure from the high pressure fuel pump is reduced during return
- The high fuel pressure from the fuel rail is reduced when the pressure limiting valve is open

This also prevents pulses in the fuel line and eliminates noise transmitted by the fuel supply line through attachment points to the vehicle's body.

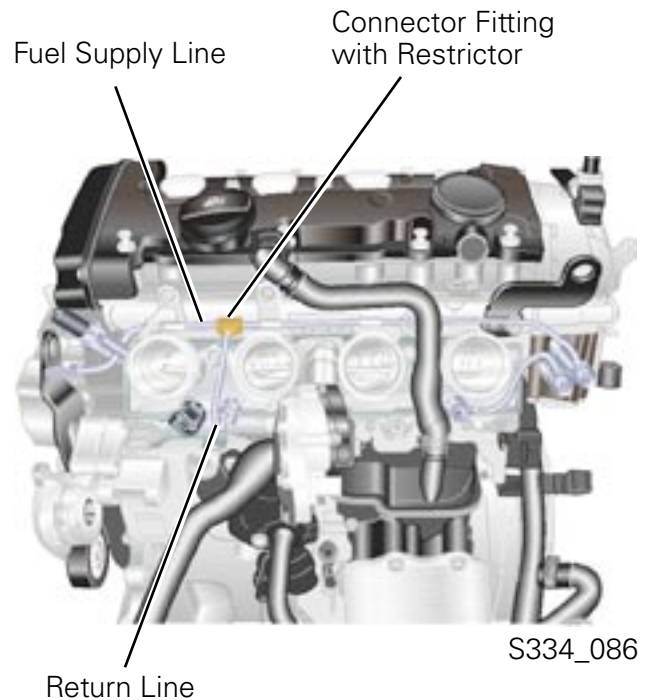

## Modes of Operation

The 2.0L turbocharged engine operates in two modes.

### Cold Start Dual Injection

Dual injection is a special mode of operation for rapid heating of the catalytic converter.

To do this, a quantity of fuel is injected on the intake stroke at approximately 300° before TDC of ignition. The fuel distributes itself homogeneously due to the long gap before ignition. The second injection occurs at approximately 60° before TDC of ignition during the compression phase.

The rich mixture that forms around the spark plug means that timing can be retarded to a considerable degree without affecting engine stability.

Dual injection also achieves stoichiometric (14.7:1) optimum air/fuel ratio. With the exhaust valves open, the exhaust temperature increases rapidly bringing the catalytic converter up to operating temperature 662°F (350°C) very quickly (30–40 seconds).

### Normal Mode

The normal mode of operation occurs with the catalytic converter at operating temperature.

Normal injection timing occurs because additional heating of the catalytic converter is no longer necessary.

The oxygen sensor reaches and maintains a lambda value of 1 (stoichiometry).

The electric fuel pump remains energized after the engine reaches operating temperature to maintain pressure in the fuel line and prevent heat bubbles in the fuel.

### Low Pressure System Prestart Operation

When the driver door is opened, the door contact switch causes the electric fuel pump to energize. The purpose of the prestart is to minimize the start time and build up fuel pressure more rapidly.

A counter monitors the number of prestarts and prevents pump damage.

# Engine Management

## Actuators and Sensor Diagram

- Mass Air Flow (MAF) Sensor G70
- Charge Air Pressure Sensor G31
- Manifold Absolute Pressure (MAP) Sensor G71
  
- Engine Speed (RPM) Sensor G28
  
- Camshaft Position (CMP) Sensor G40
- Throttle Drive Angle Sensor 1  
[for Electronic Power Control (EPC)] G187
- Throttle Drive Angle Sensor 2  
[for Electronic Power Control (EPC)] G188
- Throttle Valve Control Module J338
  
- Throttle Position (TP) Sensor G79
- Accelerator Pedal Position Sensor 2 G185
- Brake Light Switch F
- Brake Light Switch F63
  
- Fuel Pressure Sensor G247
  
- Intake Manifold Runner Position Sensor G336
  
- Knock Sensor (KS) 1 G61
- Knock Sensor (KS) 2 G66
  
- Engine Coolant Temperature (ECT) Sensor G62
- Engine Coolant Temperature (ECT) Sensor  
(on Radiator) G83
  
- Low Fuel Pressure Sensor G410
  
- Intake Air Temperature (IAT) Sensor G42
- Heated Oxygen Sensor (HO2S) G39
- Oxygen Sensor (O2S) Behind Three Way  
Catalytic Converter (TWC) G130
- Exhaust Gas Temperature (EGT) Sensor 1 G235
- Clutch Position Sensor G476
  
- Alternator DF

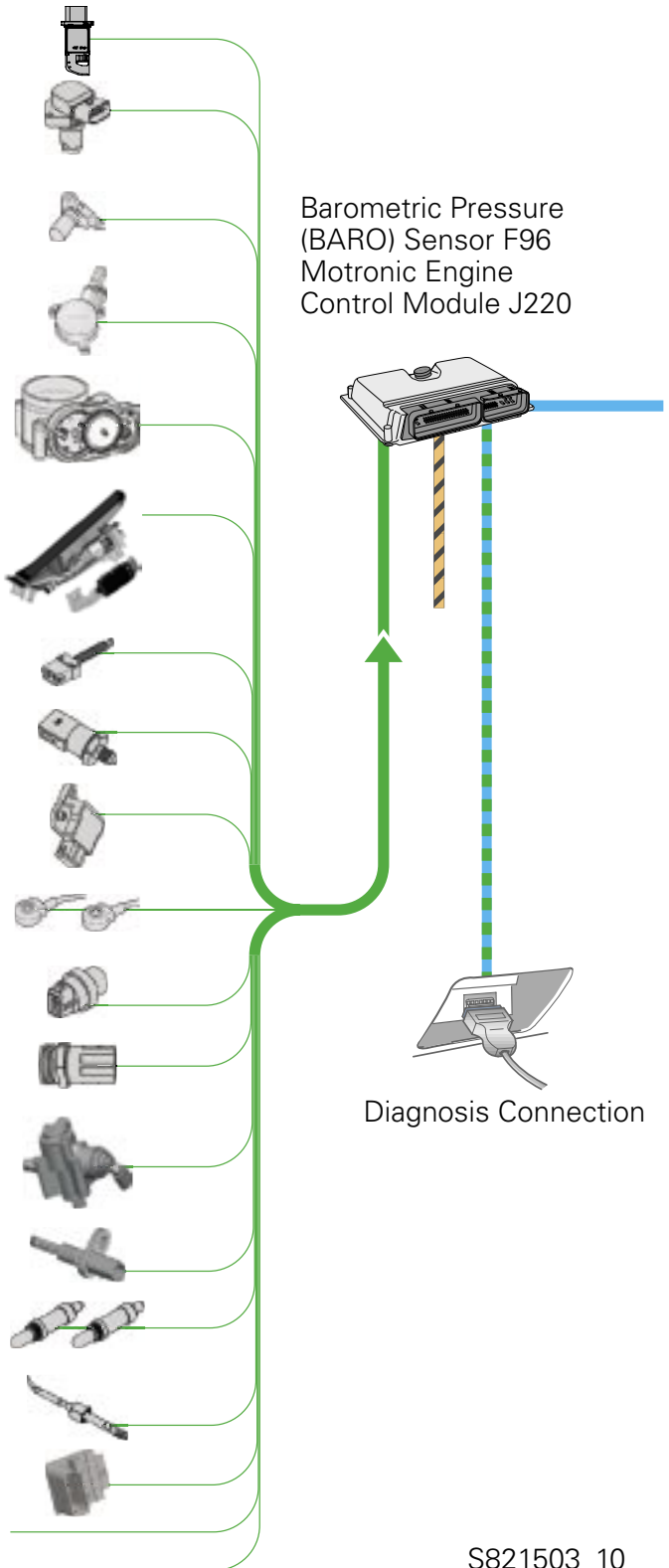

S821503\_10

# Engine Management

Fuel Pump (FP)  
Control Module J538

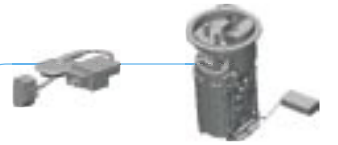

Cruise Control On/Off  
Fuel Level Sensor G  
Transfer Fuel Pump (FP) G6



Fuel Injectors N30-N33



Ignition Coil with Power Output Stage  
N70, N127, N291, N292

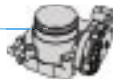

Throttle Valve Control Module J338  
Throttle Drive [for Electronic Power Control (EPC)] G186



Motronic Engine Control Module (ECM)



Power Supply Relay J271



Engine Component Power Supply Relay J757

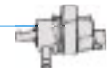

Power Supply Relay (Terminal 15) J329



Evaporative Emission (EVAP) Canister  
Purge Regulator Valve N80

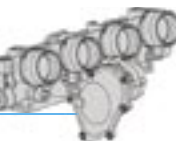

Fuel Pressure Regulator Valve N276



Intake Flap Motor V157

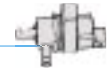

Camshaft Adjustment Valve 1 N205



Wastegate Bypass Regulator Valve N75



Turbocharger Recirculating Valve N249



Oxygen Sensor (O2S) Heater Z19  
Oxygen Sensor (O2S) Heater 1 [behind  
Three Way Catalytic Converter (TWC)] Z29



Coolant Circulation Pump Relay J151



After-Run Coolant Pump V51



Coolant Fan Control (FC) Control Module J293

S821503\_11

# Engine Management

## Functional Diagram

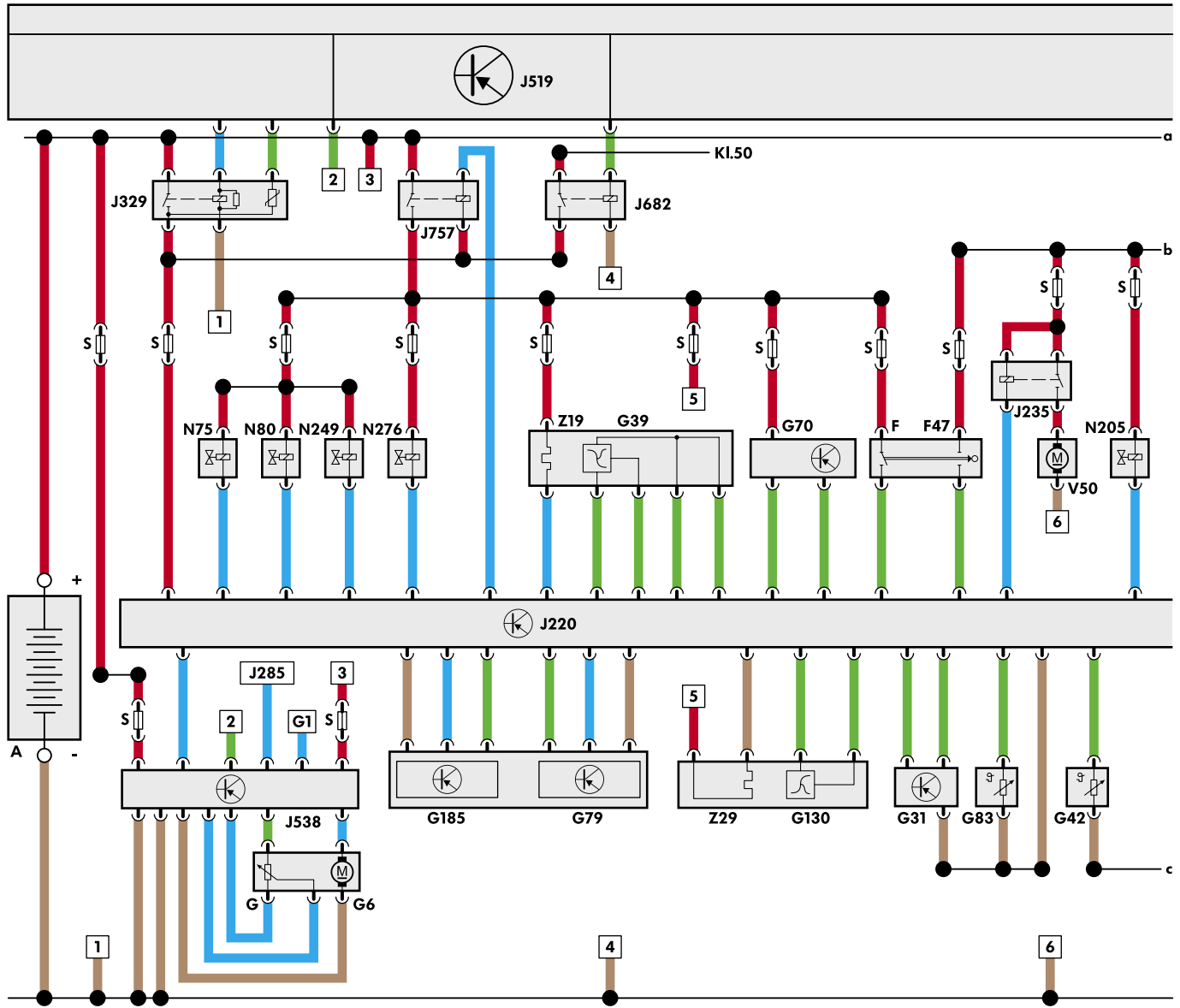

- |     |   |      |  |
|-----|---|------|--|
| A   | Battery   | G130 | Oxygen Sensor (O2S) Behind Three Way Catalytic Converter           |
| F   | Brake Light Switch                                    | G185 | Accelerator Pedal Position Sensor 2                                |
| F47 | Brake Pedal Switch                                    | G186 | Throttle Drive (for Electronic Power Control (EPC))                |
| G   | Fuel Level Sensor                                     | G187 | Throttle Drive Angle Sensor 1 (for Electronic Power Control (EPC)) |
| G1  | Fuel Gauge  | G188 | Throttle Drive Angle Sensor 2 (for Electronic Power Control (EPC)) |
| G6  | Transfer Fuel Pump (FP)                               | G247 | Fuel Pressure Sensor   |
| G28 | Engine Speed (RPM) Sensor                             |      |  |
| G31 | Charge Air Pressure Sensor                            |      |  |
| G39 | Heated Oxygen Sensor (HO2S)                           |      |  |
| G40 | Camshaft Position (CMP) Sensor                        |      |  |
| G42 | Intake Air Temperature (IAT) Sensor                   |      |  |
| G61 | Knock Sensor (KS) 1                                   |      |  |
| G62 | Engine Coolant Temperature (ECT) Sensor               |      |  |
| G66 | Knock Sensor (KS) 2                                   |      |  |
| G70 | Mass Air Flow (MAF) Sensor                            |      |  |
| G79 | Throttle Position (TP) Sensor                         |      |  |
| G83 | Engine Coolant Temperature (ECT) Sensor (on Radiator) |      |  |
- Key**
- Output Signal
  - Ground
  - Input Signal
  - Positive
  - CAN Drive Train

# Engine Management

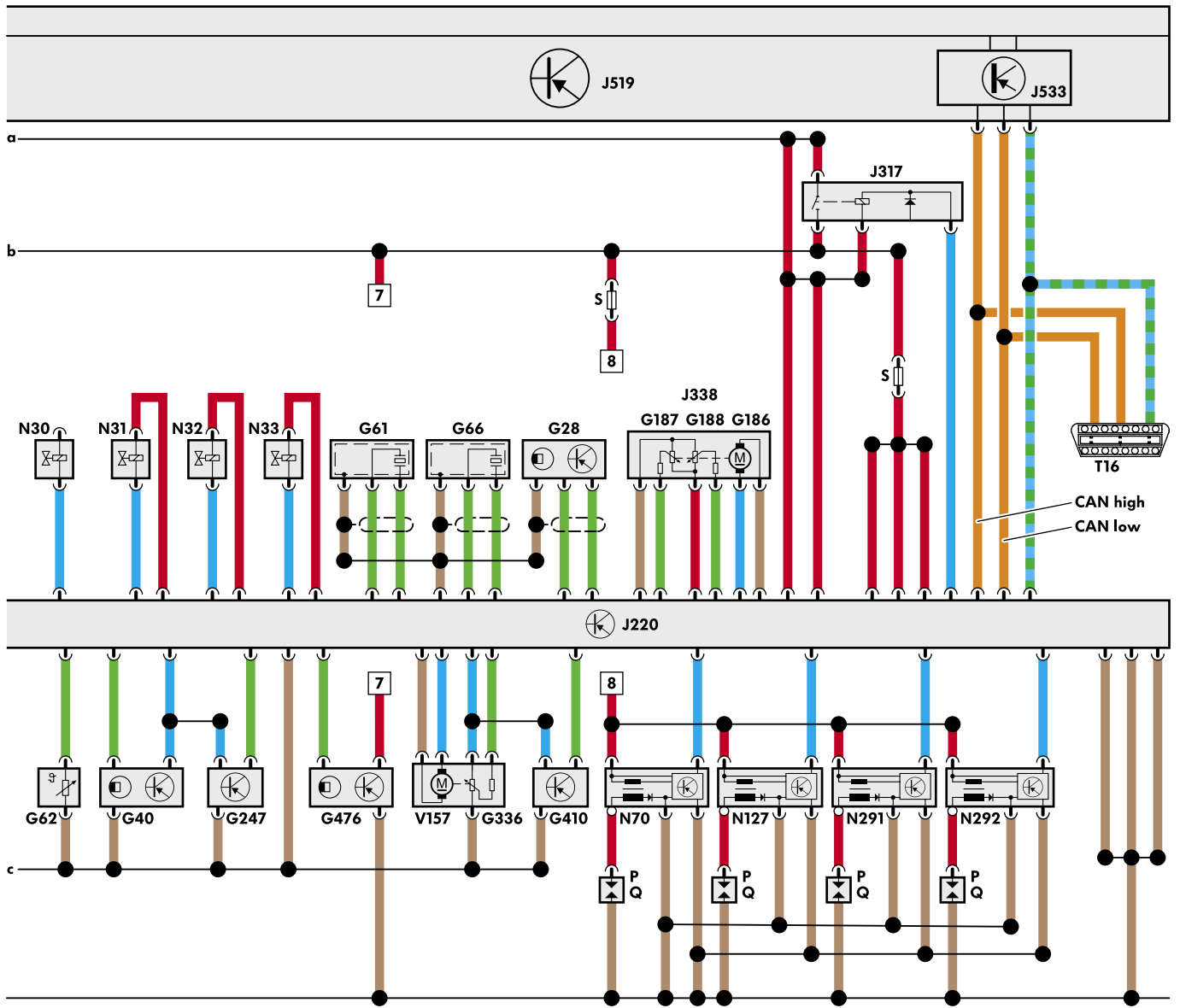

S337\_025

- G336 Intake Manifold Runner Position Sensor
- G410 Low Fuel Pressure Sensor
- G476 Clutch Position Sensor
- J220 Motronic Engine Control Module (ECM)
- J235 Engine Coolant Pump Relay
- J285 Instrument Cluster Control Module
- J317 Power Supply Relay (Terminal 30, B+)
- J329 Power Supply Relay (Terminal 15)
- J338 Throttle Valve Control Module
- J519 Vehicle Electrical System Control Module
- J533 Data Bus On Board Diagnostic
- J538 Fuel Pump (FP) Control Module
- J682 Power Supply Relay (Terminal 50)
- J757 Engine Component Power Supply Relay
- N30 Cylinder 1 Fuel Injector
- N31 Cylinder 2 Fuel Injector
- N32 Cylinder 3 Fuel Injector
- N33 Cylinder 4 Fuel Injector
- N70 Ignition Coil 1 With Power Output Stage

- N75 Wastegate Bypass Regulator Valve
- N80 Evaporative Emission (EVAP) Canister Purge Regulator Valve
- N127 Ignition Coil 2 with Power Output Stage
- N205 Camshaft Adjustment Valve 1
- N249 Turbocharger Recirculating Valve
- N276 Fuel Pressure Regulator Valve
- N291 Ignition Coil 3 with Power Output Stage
- N292 Ignition Coil 4 with Power Output Stage
- P Spark Plug Connectors
- Q Spark Plugs
- S Fuse
- T16 16-Pin Connector
- V50 Coolant Pump
- V157 Intake Flap Motor
- Z19 Oxygen Sensor (O2S) heater
- Z29 Oxygen Sensor (O2S) Heater 1 (Behind Three Way Catalytic Converter (TWC))



# Service

---

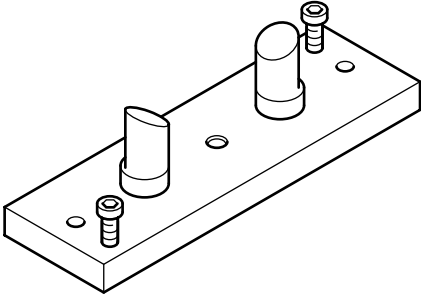
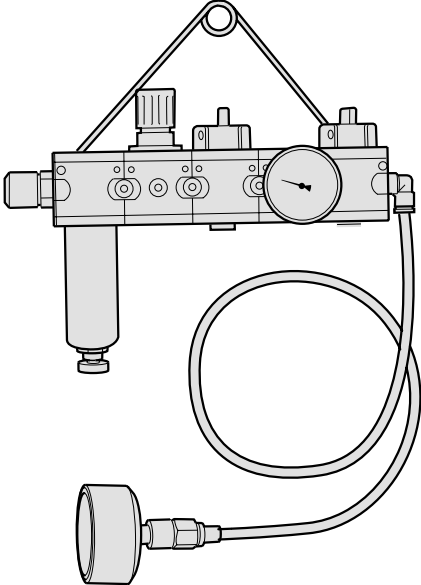
## Special Tools

Designation	Tool	Application
T10252 Camshaft bar	 A technical drawing of a rectangular metal bar with two cylindrical pins of different heights and two screws on top, used for locking a camshaft.	Locks camshaft to allow pulley removal
VAG 1687 Charge air system tester	 A technical drawing of a VAG 1687 charge air system tester. It features a central gauge, several control valves, and a pressure hose with a circular air filter.	To check for leaks in charge air system
With new adapter 687/5		

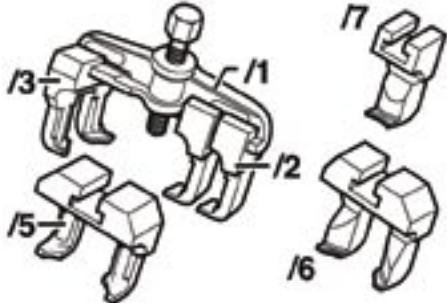

Designation	Tool	Application
<p>T10133 FSI special tool case</p>		<p>Contains tools for injector removal, injection seal installation and injector installation.</p>
<p>T40057 Oil drain adapter</p>		<p>To drain engine oil from oil filter housing</p>
<p>T40001 Puller</p>		<p>To remove camshaft pulley</p>
<p>T40001/1-7 Arms for puller</p>		

# Notes

---



# Knowledge Assessment

---

An on-line Knowledge Assessment (exam) is available for this Self-Study Program.

The Knowledge Assessment may or may not be required for Certification.

You can find this Knowledge Assessment at:

**[www.vwwebservice.com](http://www.vwwebservice.com)**

From the vwwebservice.com Homepage:

- Click on the Certification tab
- Type the course number in the Search box
- Click “Go!” and wait until the screen refreshes
- Click “Start” to begin the Assessment

For Assistance, please call:

**Certification Program Headquarters**

**1 – 877 – CU4 – CERT**

**(1 – 877 – 284 – 2378)**

**(8:00 a.m. to 8:00 p.m. EST)**

Or, E-Mail:

**[Comments@VWCertification.com](mailto:Comments@VWCertification.com)**



Volkswagen of America, Inc.  
3800 Hamlin Road  
Auburn Hills, MI 48326  
Printed in U.S.A.  
August, 2005

